

3030335COM Tall Cabinet

systembuild[®]
EVOLUTION

Date of Purchase ___ / ___ / ___
Lot Number:

B343030335COM0

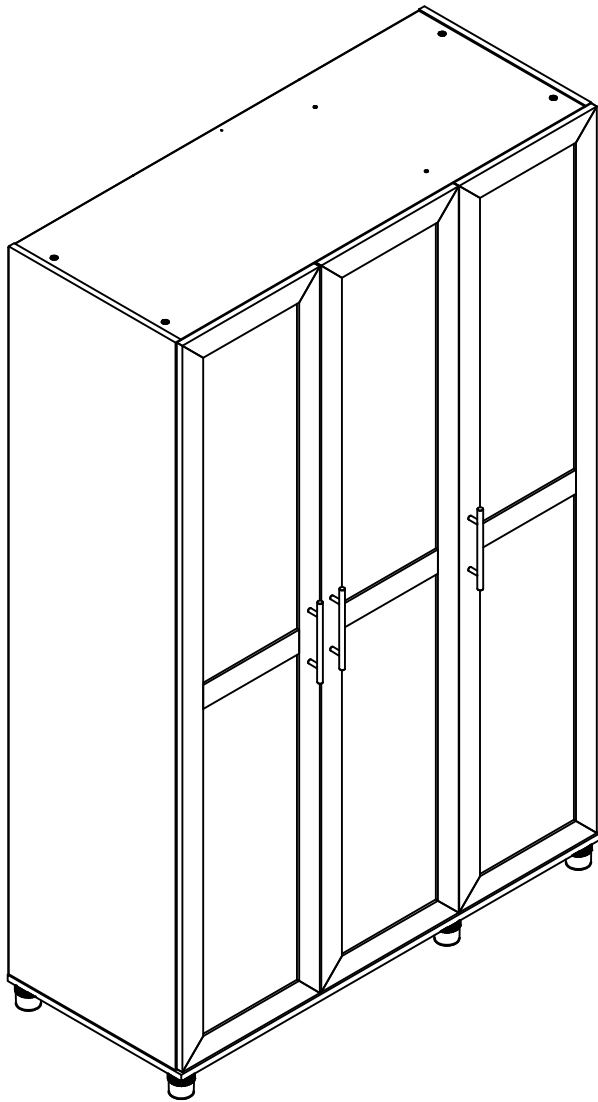

Do Not Return This Product!
Contact our customer service team for help first.
Call: 1-866-452-4081 (toll free)
Monday-Friday 9am - 5pm CST
Visit: www.systembuild.com

THIS INSTRUCTION BOOKLET CONTAINS **IMPORTANT** SAFETY INFORMATION. PLEASE READ AND KEEP FOR FUTURE REFERENCE.

Secure Your Furniture

Keep your home and family safe with the wall anchor kit that is included with the product.

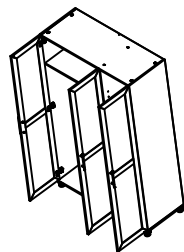

Serious or fatal crushing injuries can occur from tipping furniture.

WARNING: Manufacturer assumes no liability for improper installation or excessive loads placed on screws or bracket. This wall anchor is not a substitute for proper adult supervision.

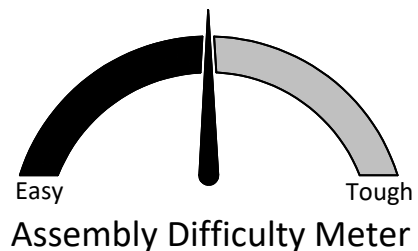

For the latest information on SystemBuild products
follow us at Ameriwood Home



Contact Us!

Do NOT return this product!

Contact our friendly customer service team first for help.

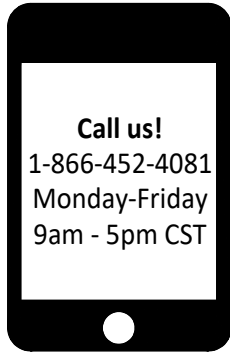

Visit systembuild.com to view the limited warranty valid in the U.S. and Canada.

Assembly Tips



Helpful Hints

PEOPLE NEEDED FOR ASSEMBLY: 1-2

- Open your item in the area you plan to keep it to avoid excessive heavy lifting.
- Identify, sort and count the parts before attempting assembly.
- Compression dowels are lightly tapped in with a hammer.
- Slides are labeled with a **R** (right) and **L** (left) for proper placement.
- Make sure to always face the point on the top of the Cam Lock towards the outer edge.
- Use all the nails provided for the back panel and spread them out equally.
- Back panel must be used to make sure your unit is sturdy.
- Do NOT use harsh chemicals or abrasive cleaners on this item.
- Never push, pull, or drag your furniture.



Before You Start

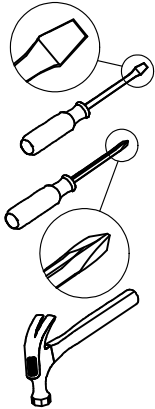
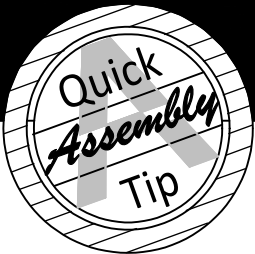

- ✓ Read through each step carefully and follow the proper order
- ✓ Separate and count all your parts and hardware
Parts are labeled on the surface or edge of the part
- ✓ Give yourself enough room for the assembly process
- ✓ Have the following tools: Flat Head Screwdriver, #2 Phillips Head Screwdriver and Hammer
- ✓ Caution: If using a power drill or power screwdriver for screwing, please be aware to slow down and stop when screw is tight. Failure to do so may result in stripping the screw.

Cam Lock Fastening System

This Cam Lock Fastening System will be used throughout the assembly process.

1

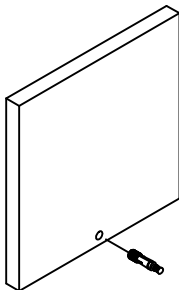

Press CAM BOLT into hole.

2

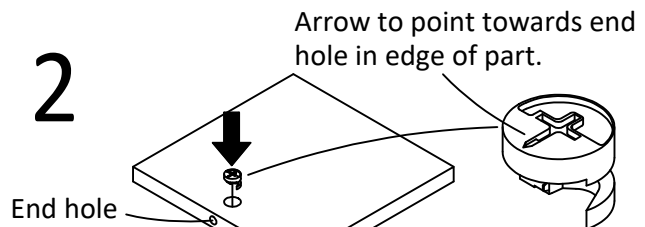

Press CAM LOCK into hole.

3

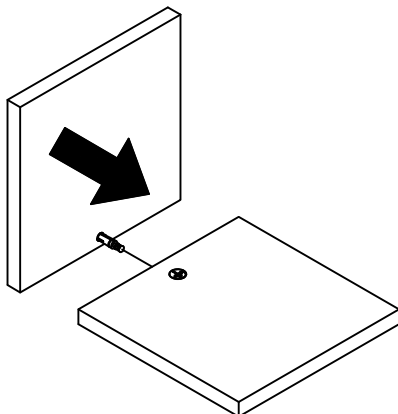

Press parts together so CAM BOLT inserts into edge hole.

4

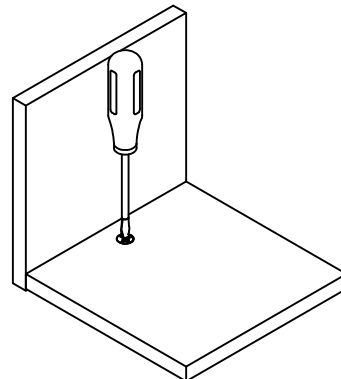

Using a screwdriver, turn the CAM LOCK clockwise to lock the CAM LOCK and CAM BOLT into their holes and fastening parts together.

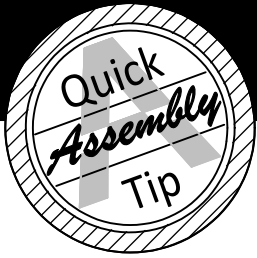

Before You Start

Please Note:
You may need to lightly tap the wood dowels into the holes during your assembly process.

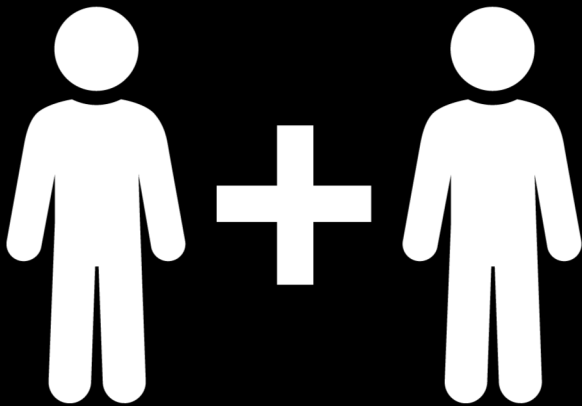
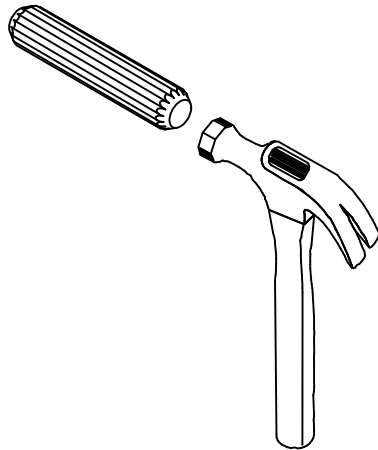

2 PEOPLE NEEDED FOR ASSEMBLY

**2 PERSONAS NECESITADAS
PARA LA ASAMBLEA**

**2 PERSONNES NÉCESSAIRES
POUR L'ASSEMBLAGE**

CAUTION: Failure to use 2 people for assembly could result in unit damage or personal injury.

PRECAUCIÓN: Si no se utilizan 2 personas para el ensamblaje, se pueden producir daños en la unidad o lesiones personales.

ATTENTION: Échec d'utiliser 2 personnes pour l'assemblage peut causer du dommage au meuble ou causer des blessures.

Board Identification

Not actual size

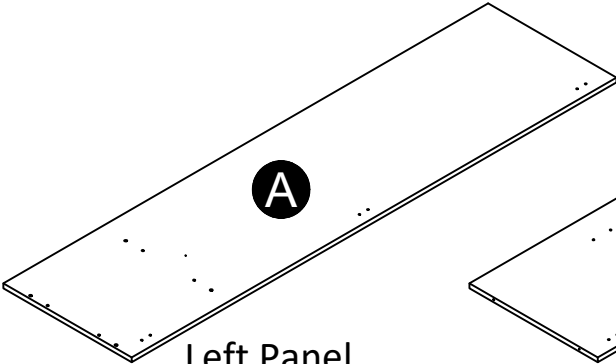

Left Panel
39304335010

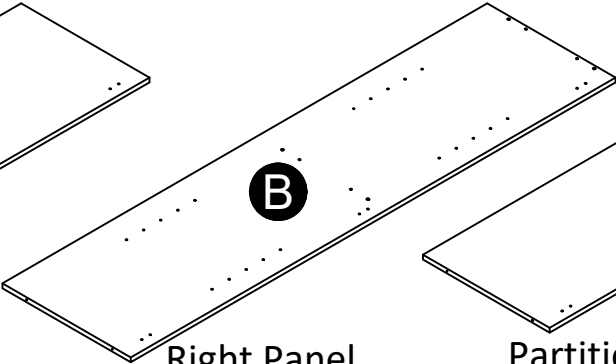

Right Panel
39304335020

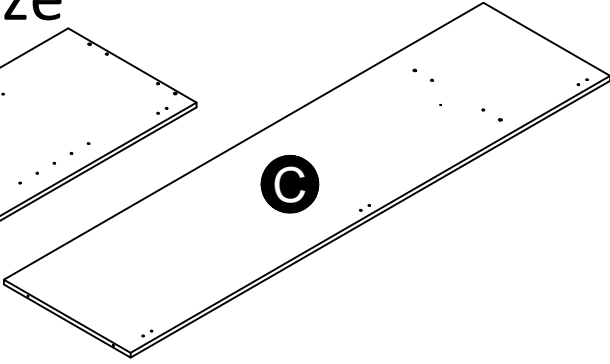

Partition
39304335030

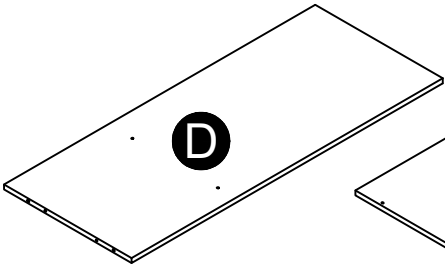

Top
39304335040

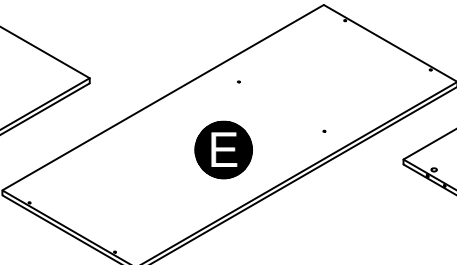

Bottom
39304335050

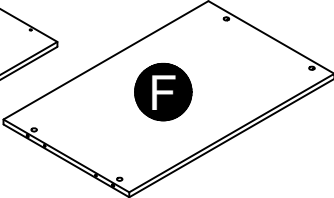

Left Shelf
39304335060

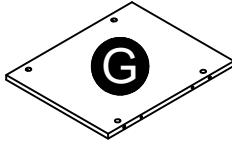

Right Shelf
39304335070

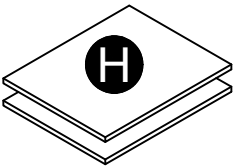

Adjustable Shelf (x2)
39304335080

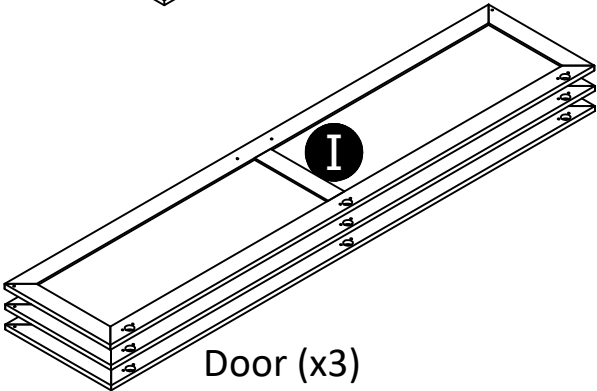

Door (x3)
33030335090

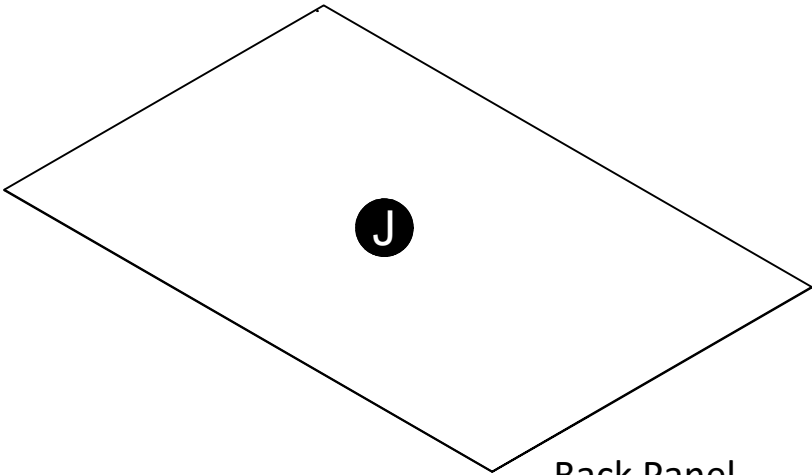

This piece is paperboard construction.
It is not made from wood, but is
required for the assembly of your unit.

Back Panel
K930433500

Board Identification

Not actual size

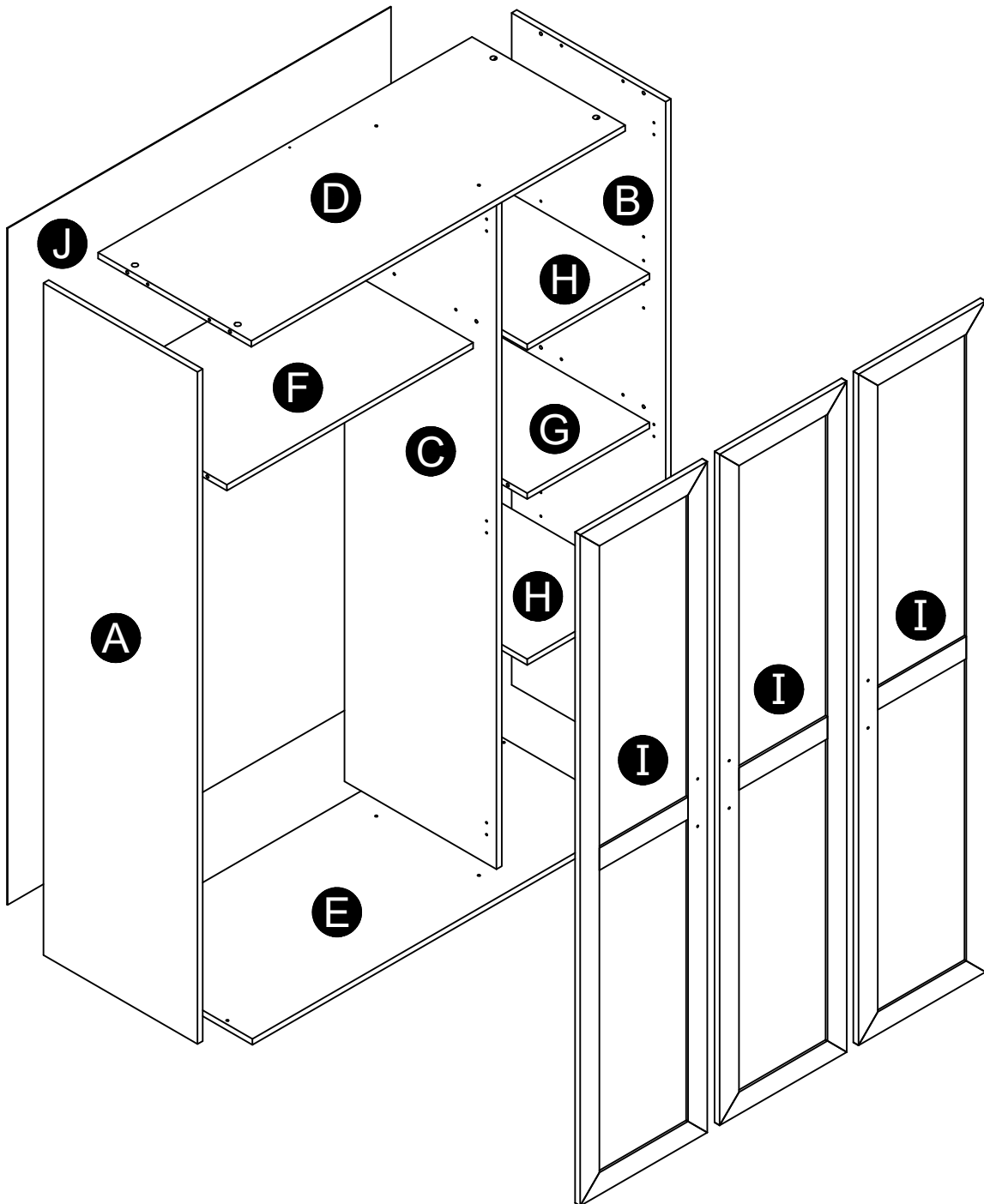

Part List

Actual Size

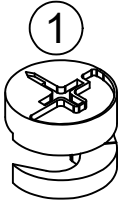

(x12)
#A22700
cam lock

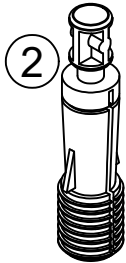

(x12)
#A22710
cam bolt



(x12)
#A21670
wood dowel

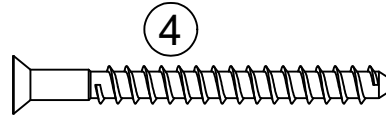

(x8)
#A23030
confirmat screw



(x48)
#A21110
nail

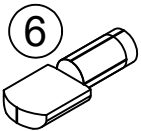

(x8)
#A80250
shelf support



(x2)
#A11080
7/16" screw



(x6)
#A17400
7/8" bolt

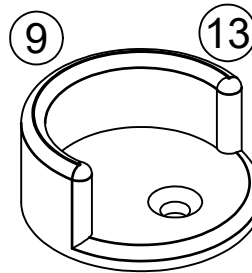

(x2)
13 - #A82010 (white)
9 - #A82020 (black)
rod bracket



(x12)
#A12420
5/8" screw



(x3)
#A89370
door bumper

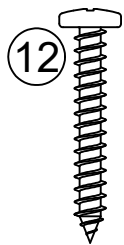

(x6)
#A12930
1-1/8" screw

Part List

Not actual size

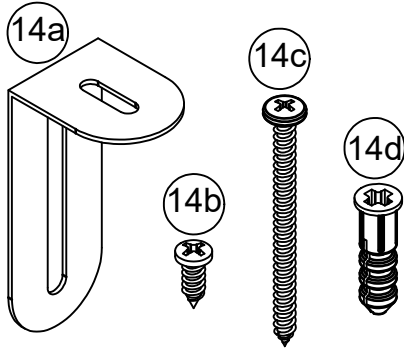

(x1)
14 #A84050
safety bracket

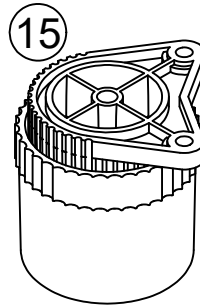

(x6)
15 #A44140
foot

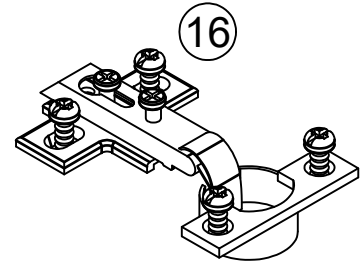

(x9)
16 #A65615
hinge

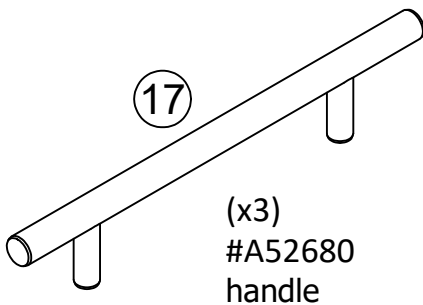

(x3)
17 #A52680
handle

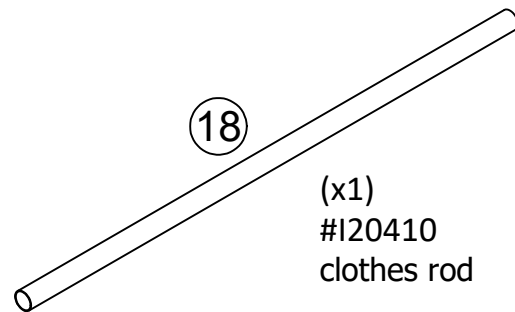

(x1)
18 #I20410
clothes rod

STEP 1

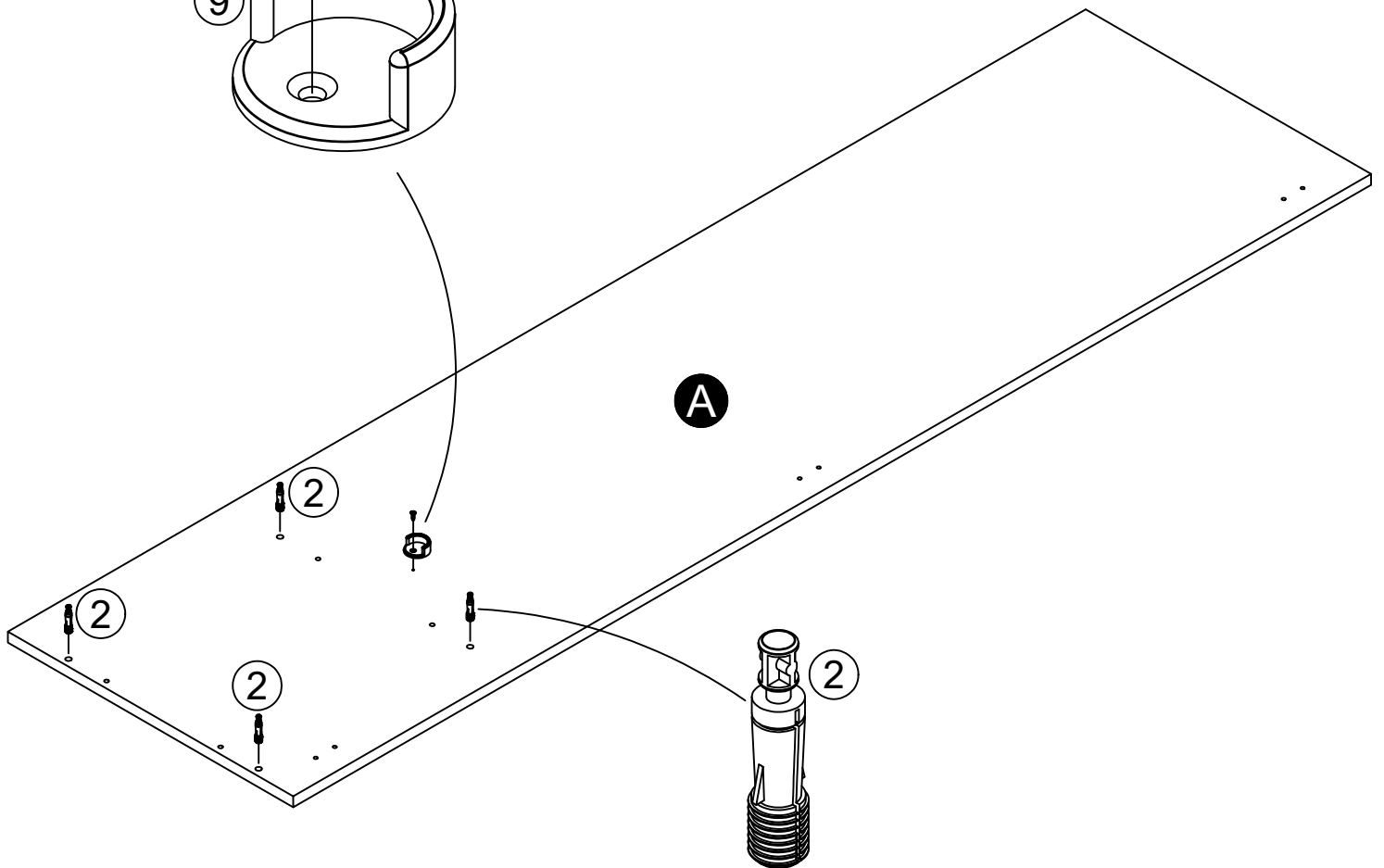
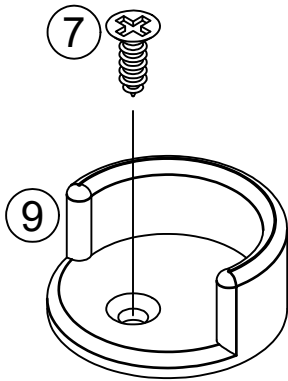
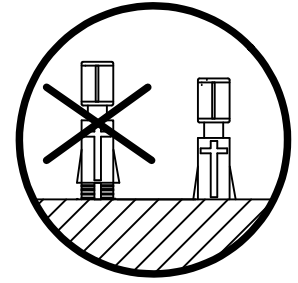
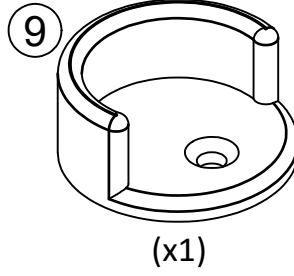
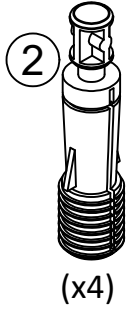
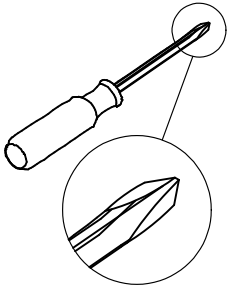

STEP 2

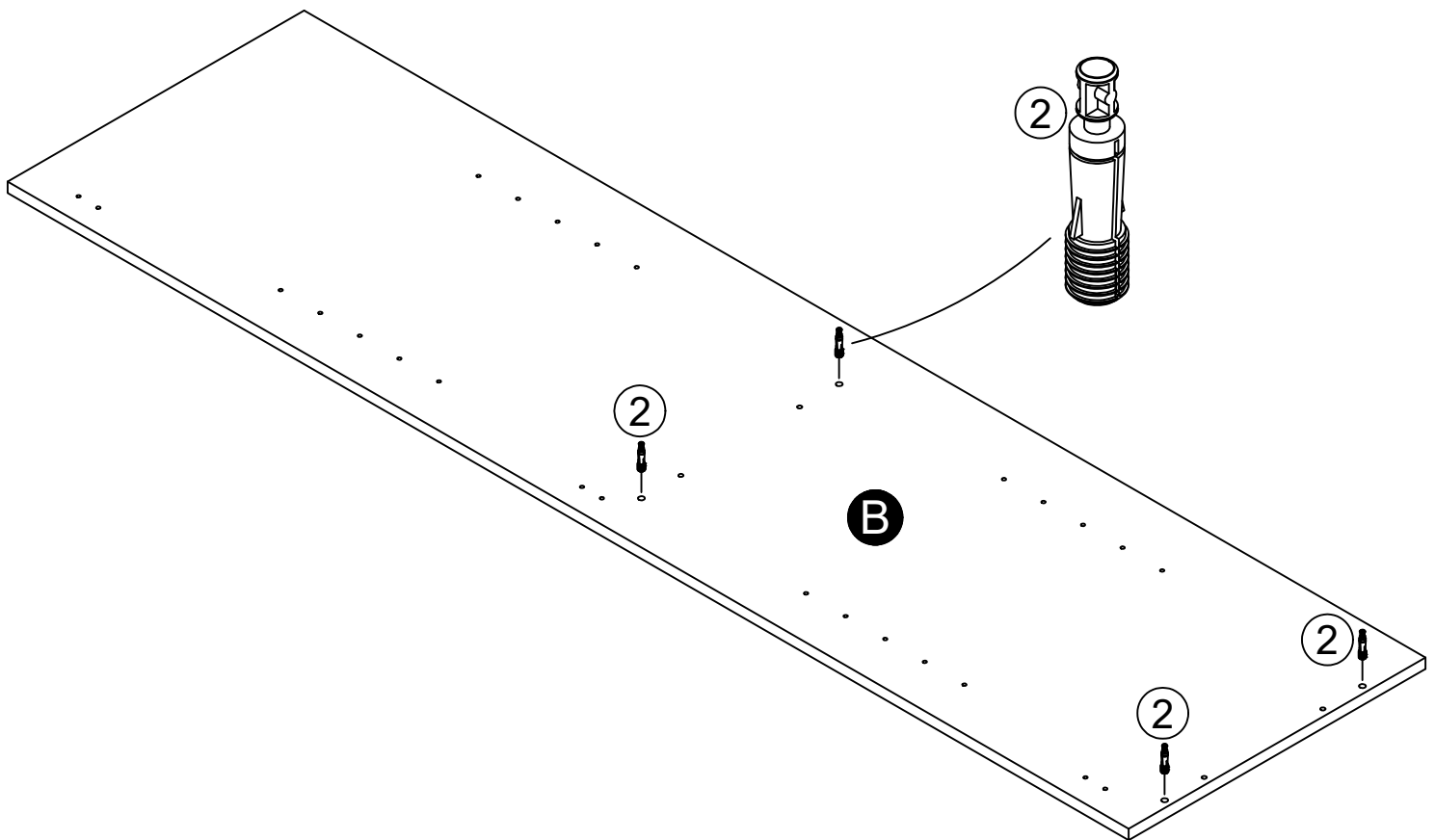
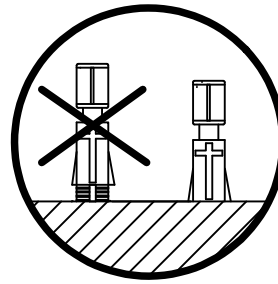
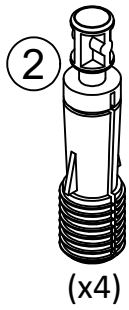

STEP 3

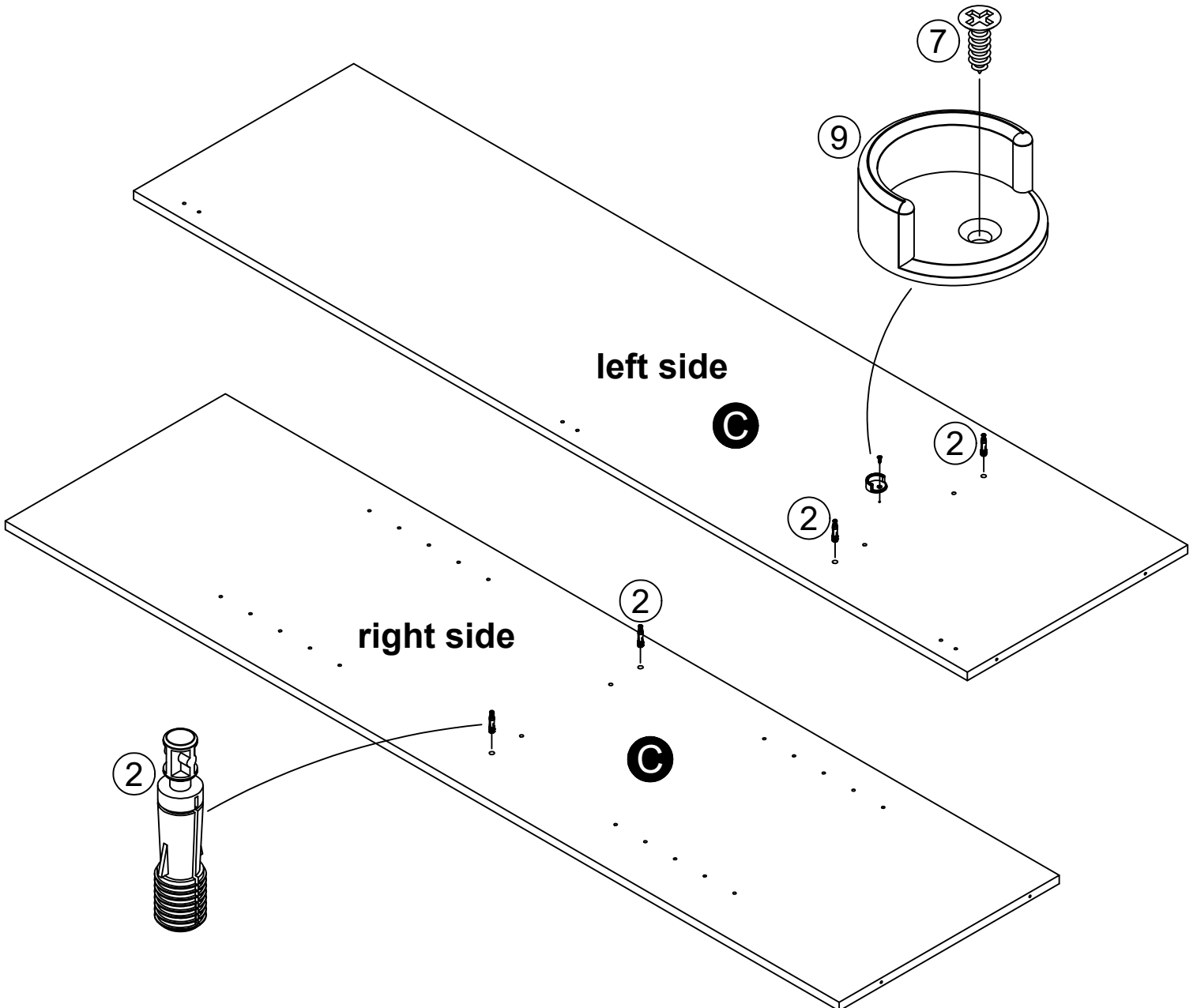
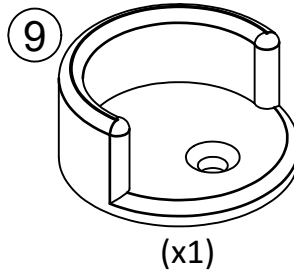
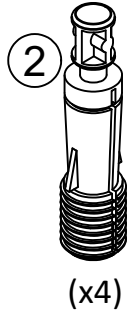
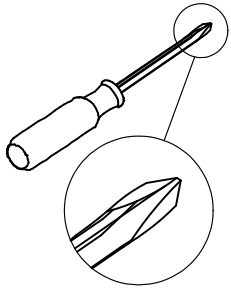

STEP 4

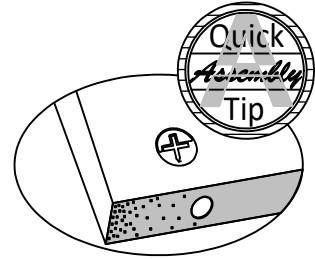
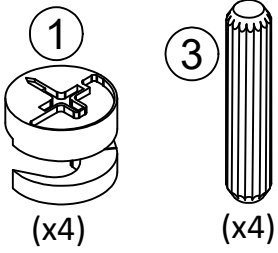

Proper orientation of CAM LOCK

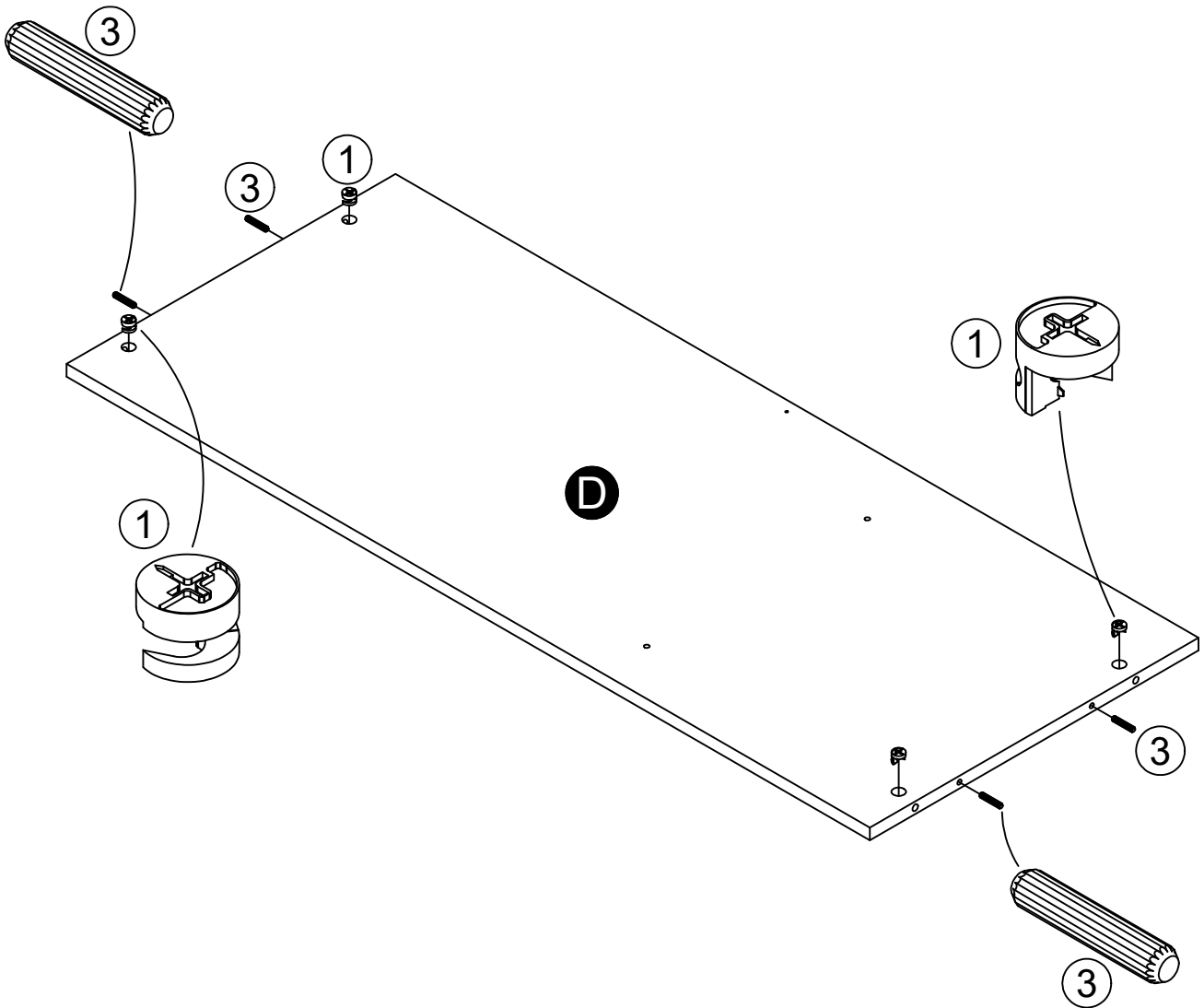

STEP 5

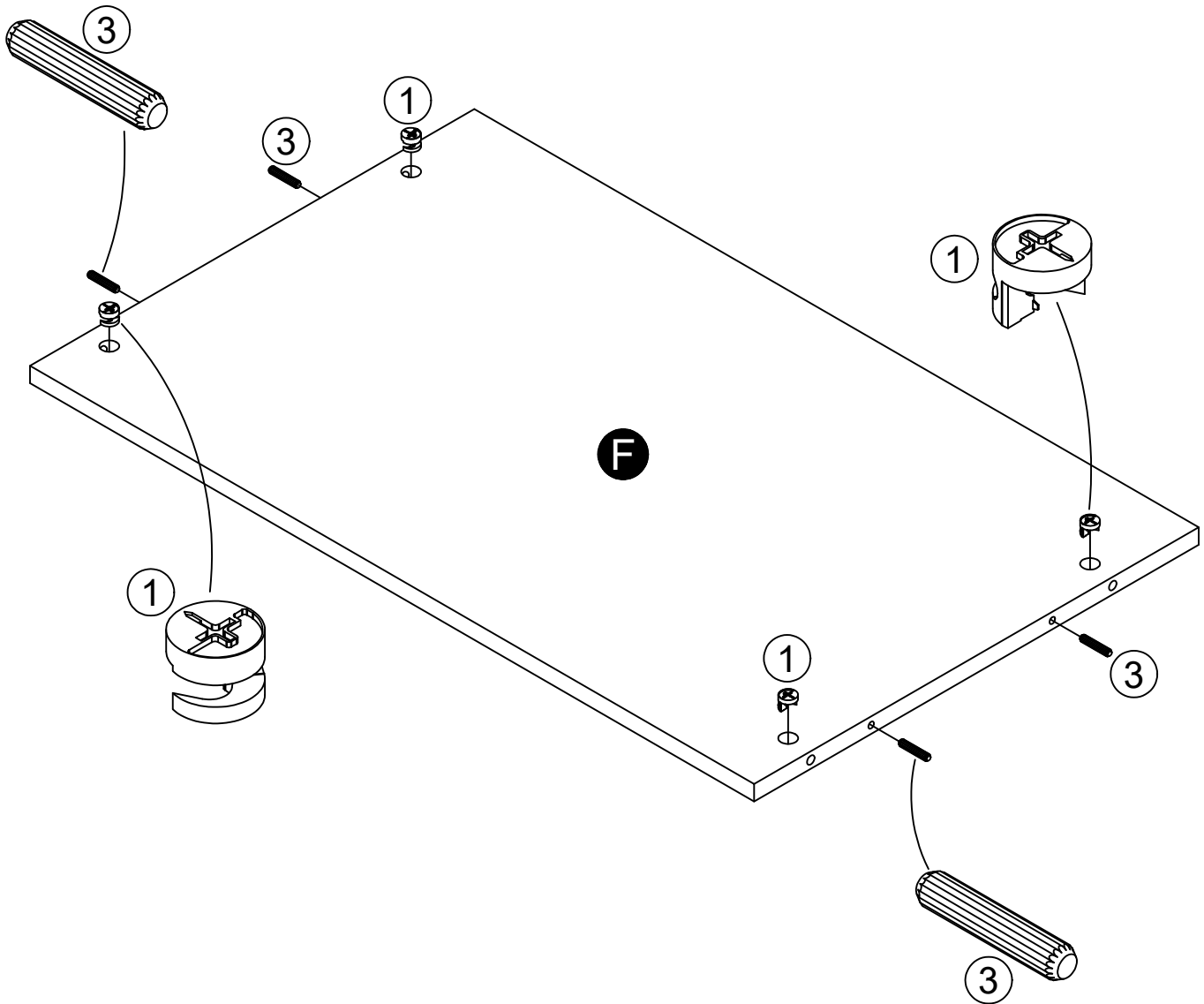
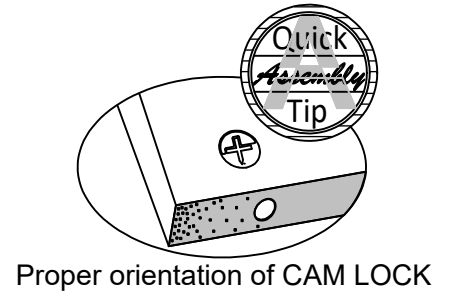
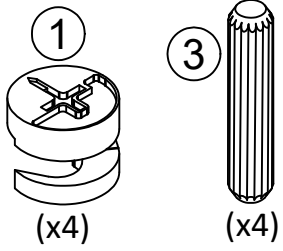

STEP 6

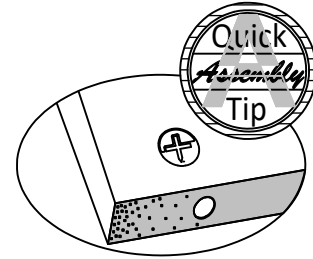
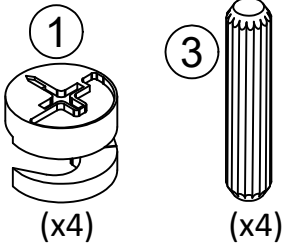

Proper orientation of CAM LOCK

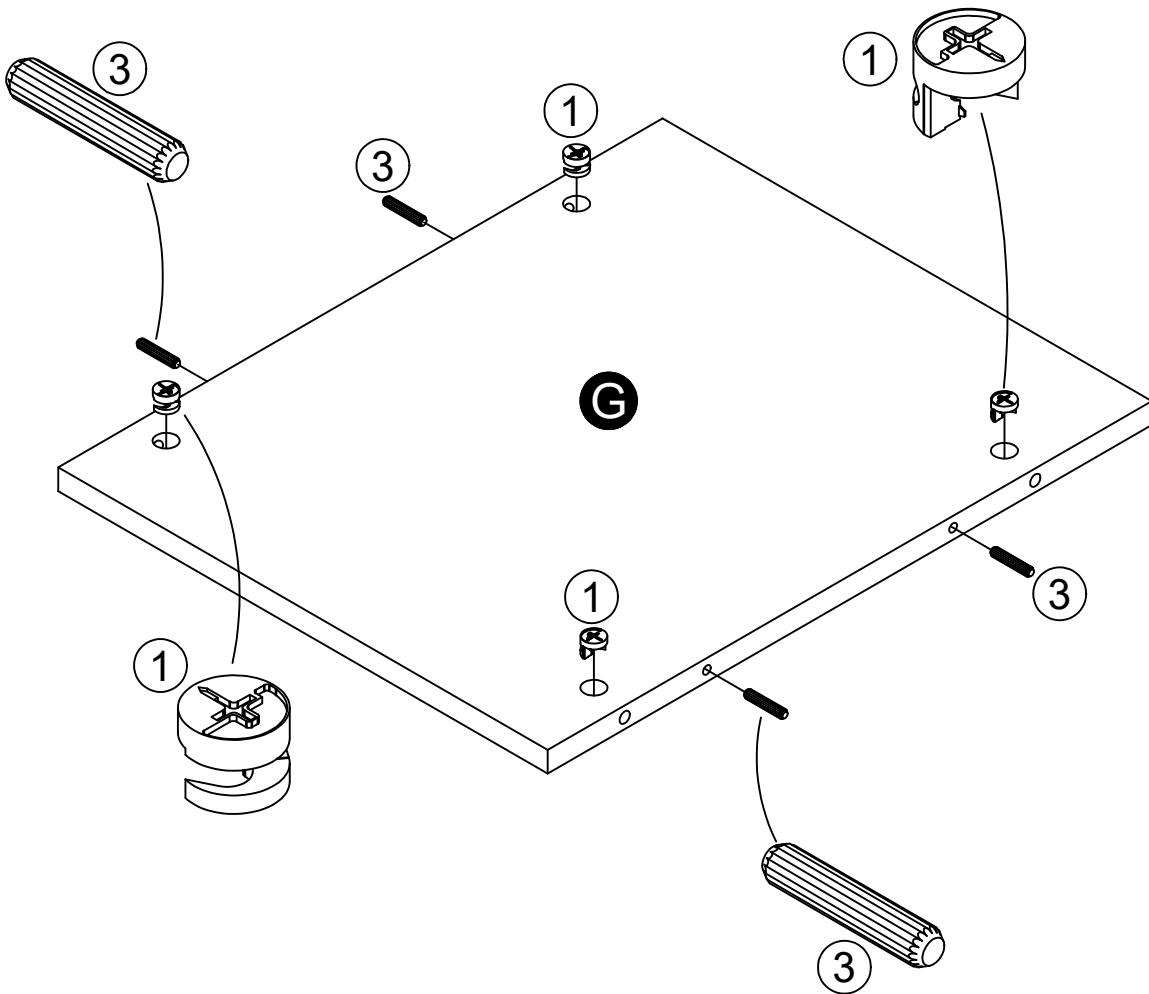

STEP 7

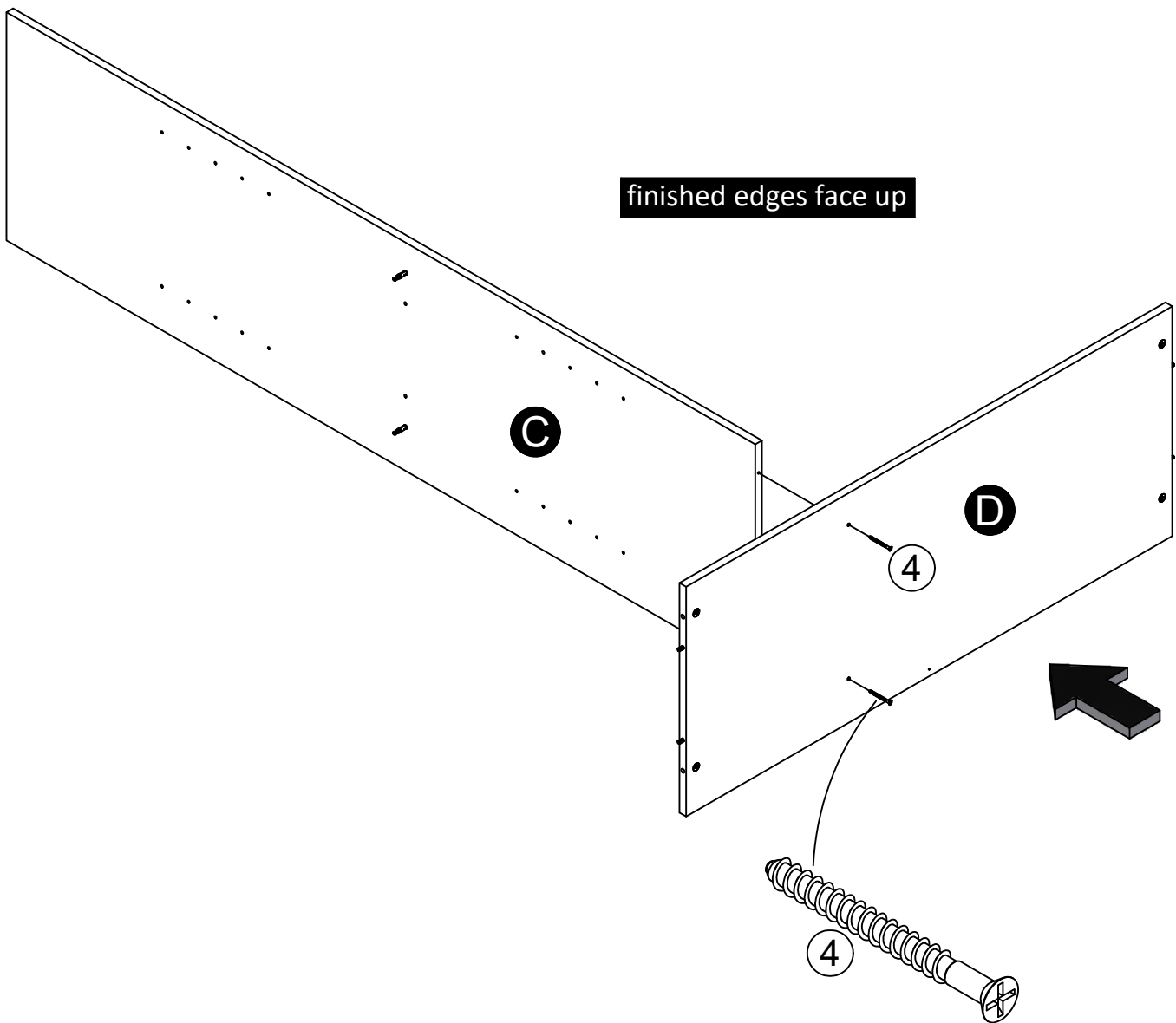
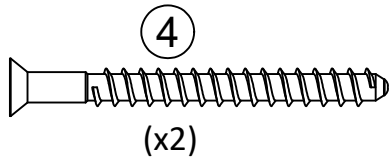
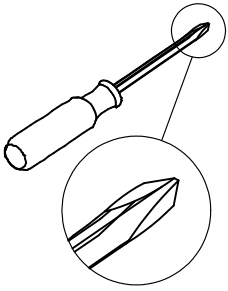

STEP 8

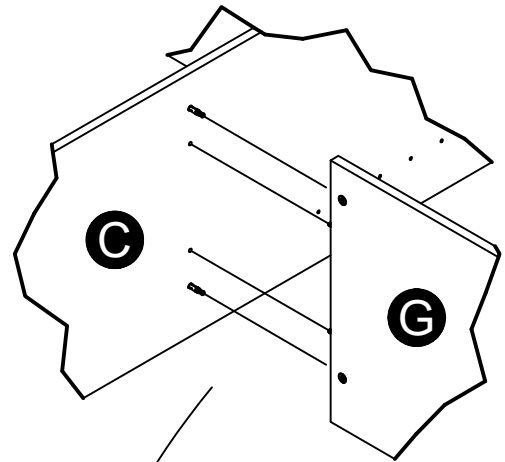
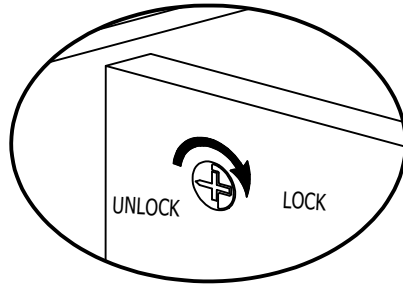
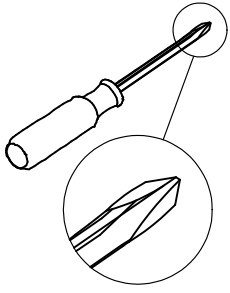

finished edges face up

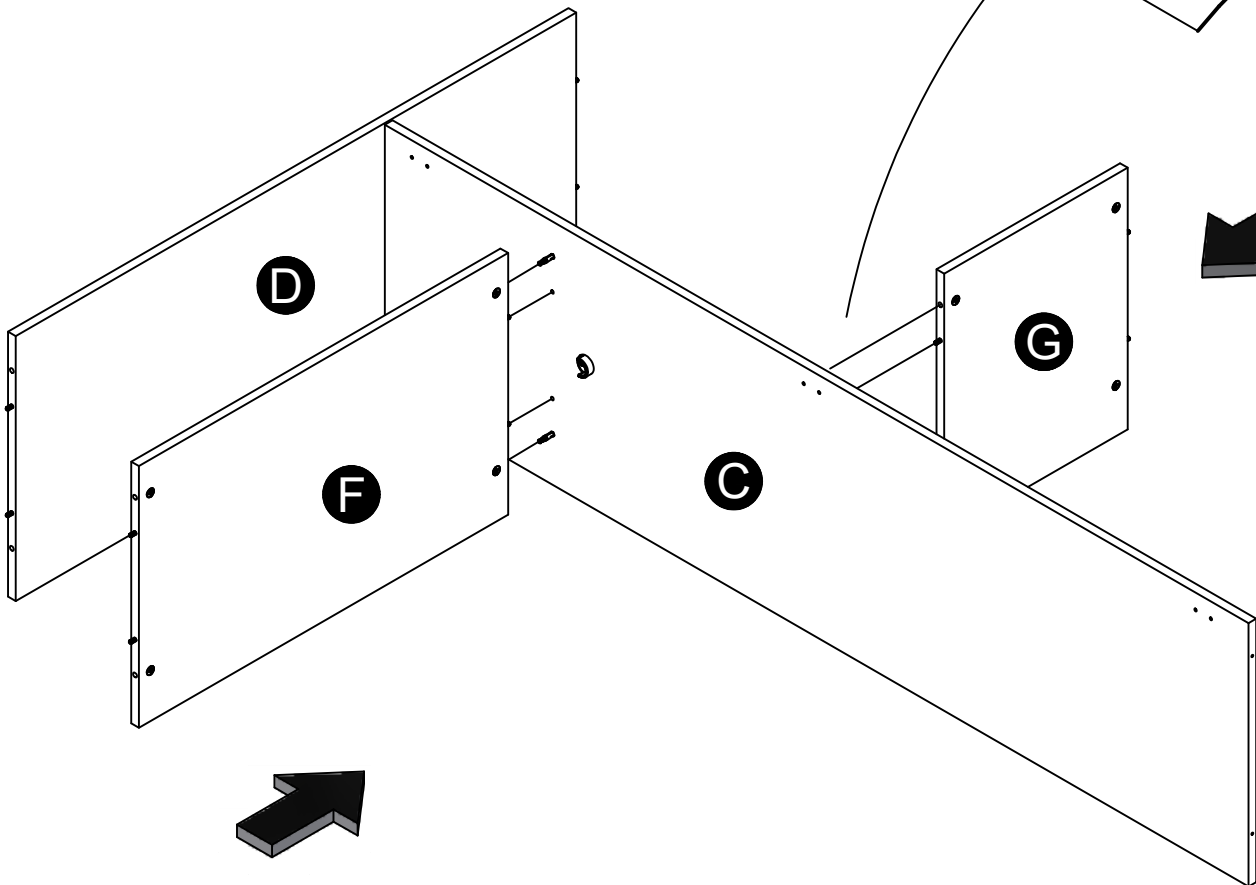

STEP 9

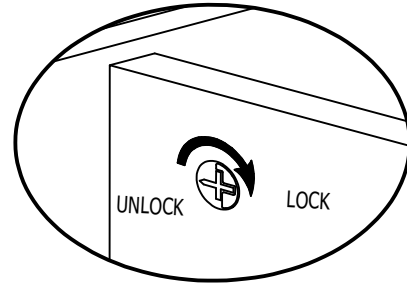
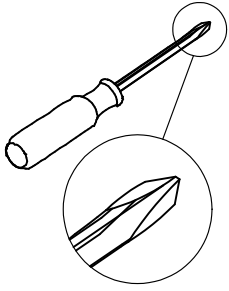

finished edges face up

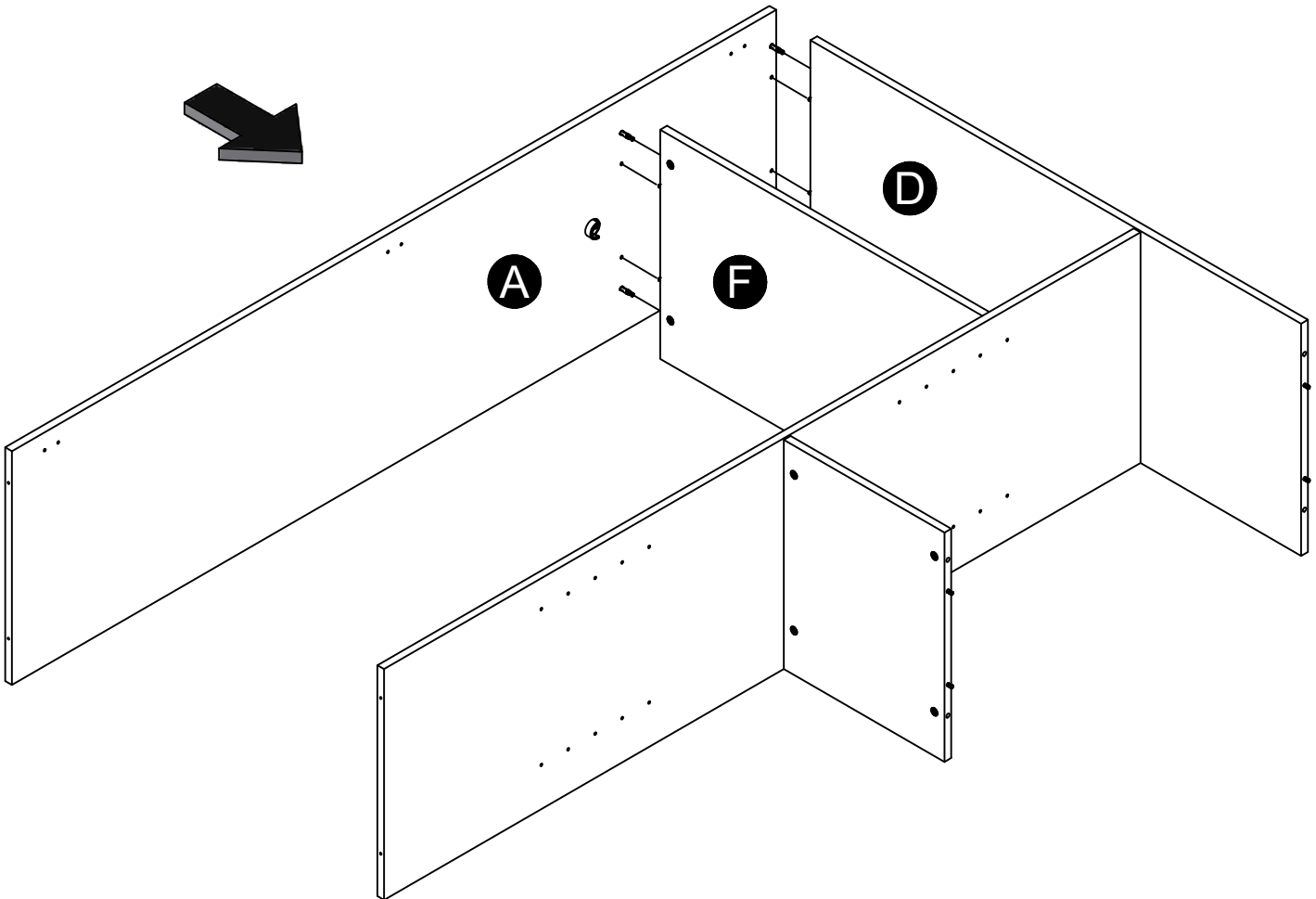
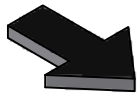

STEP 10

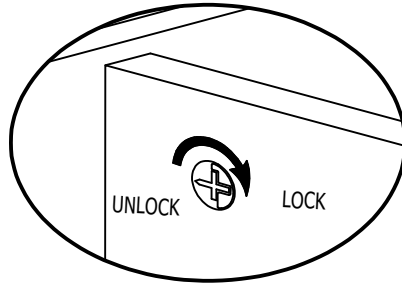
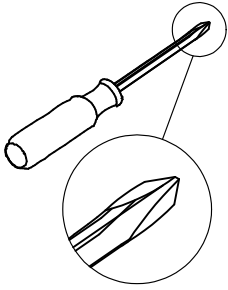

finished edges face up

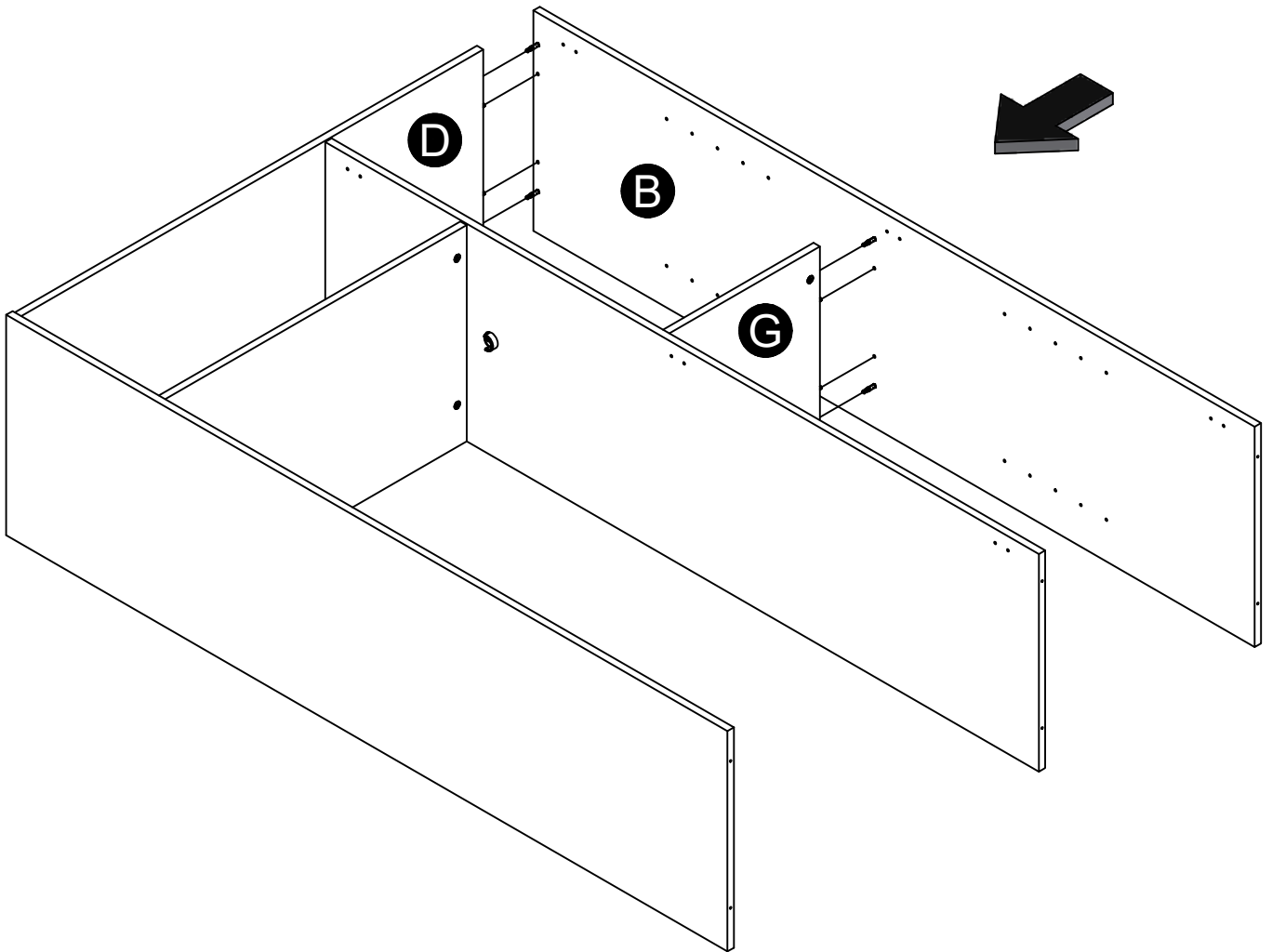

STEP 11

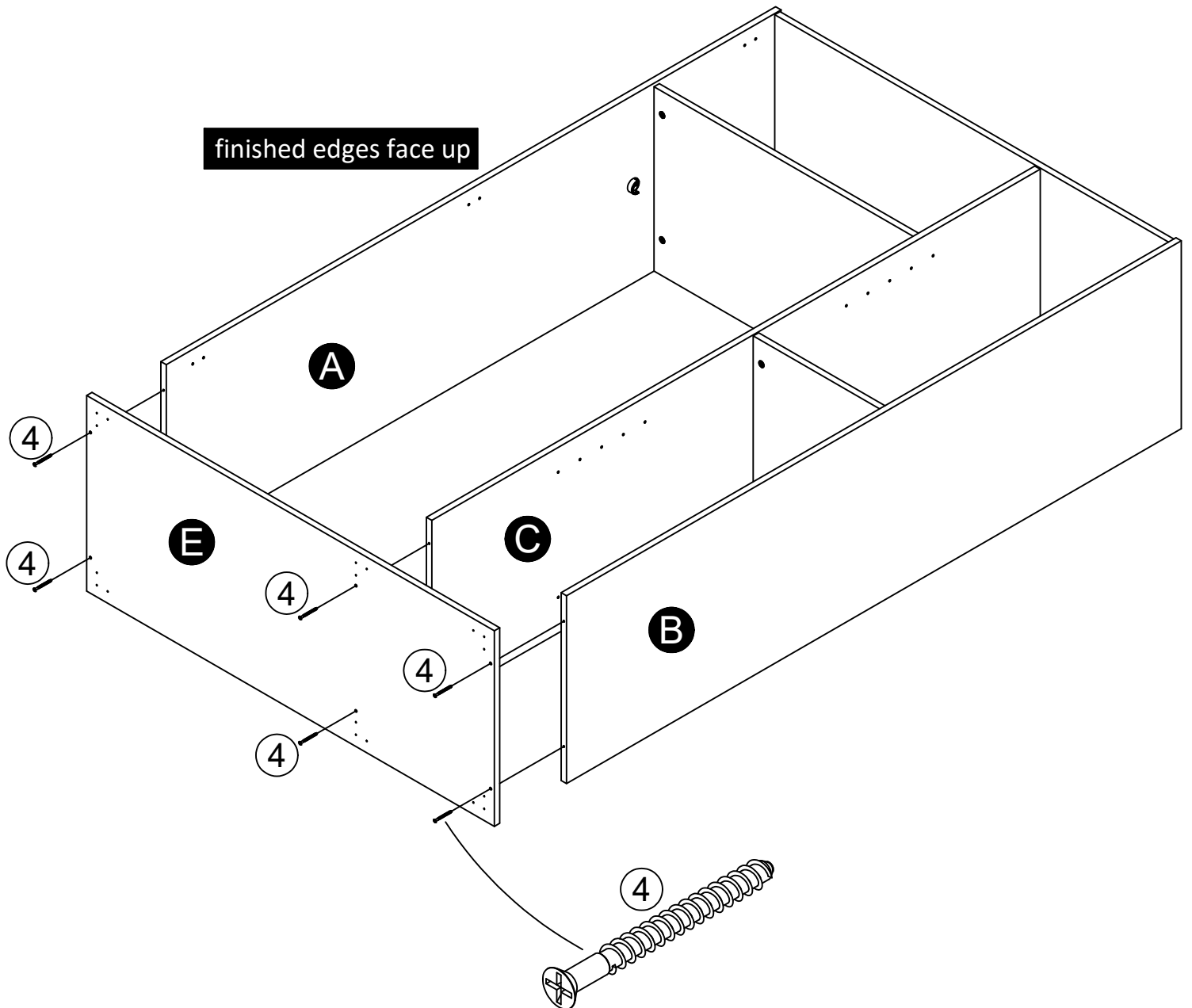
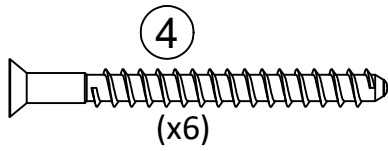
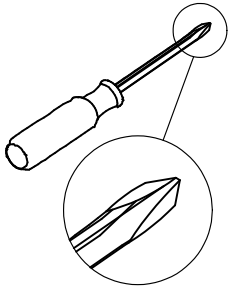

STEP 12

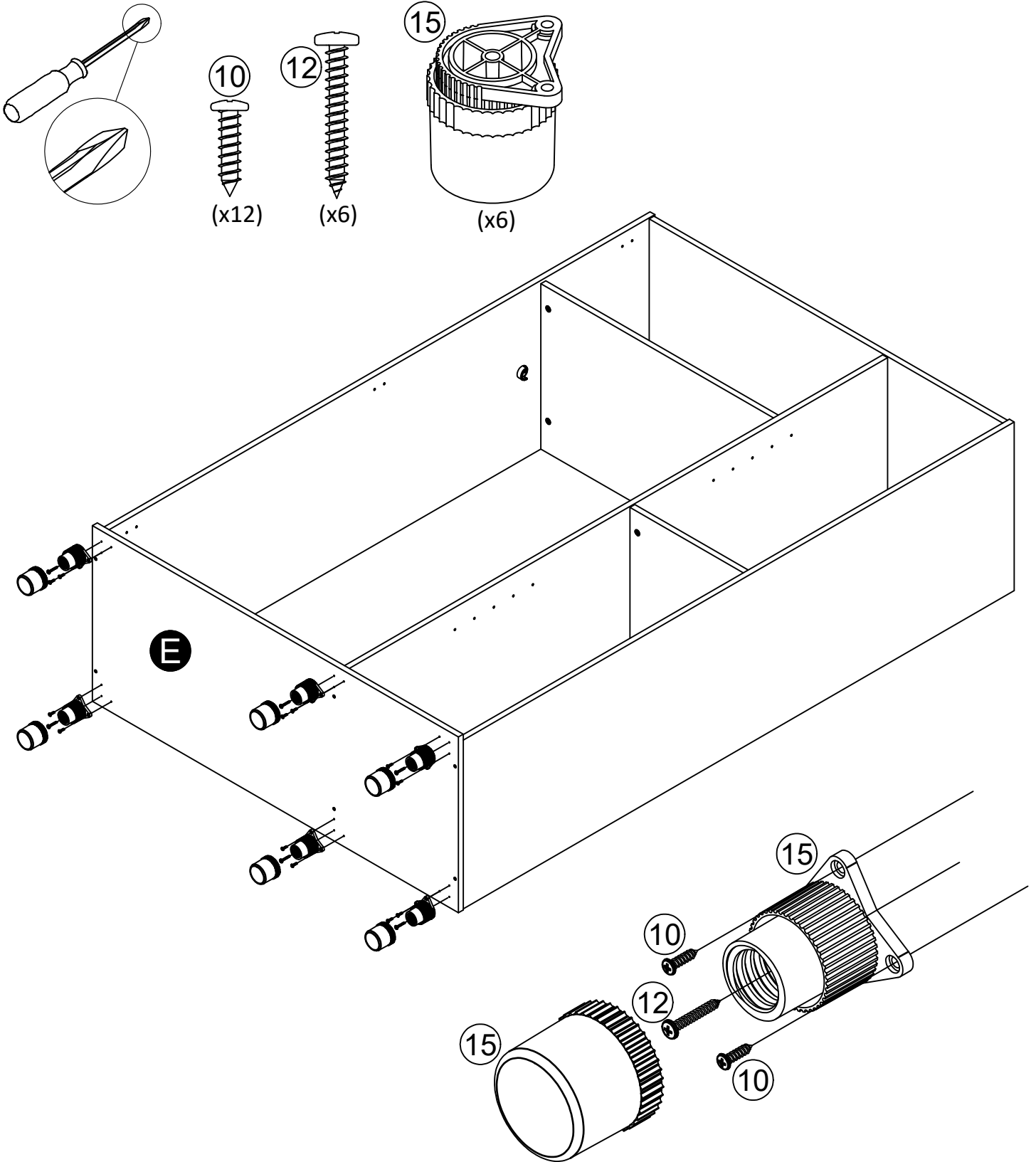

STEP 13

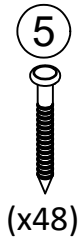
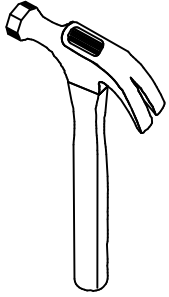

IMPORTANT! THE BACK PANEL IS A STRUCTURAL PART OF THIS UNIT AND MUST BE INSTALLED PROPERLY.

Carefully turn your unit on its front side.

Attached the back panel as shown nailing straight into the raw edges.

Assure that our unit is square.
Distance from corner to corner
must be equal as shown.

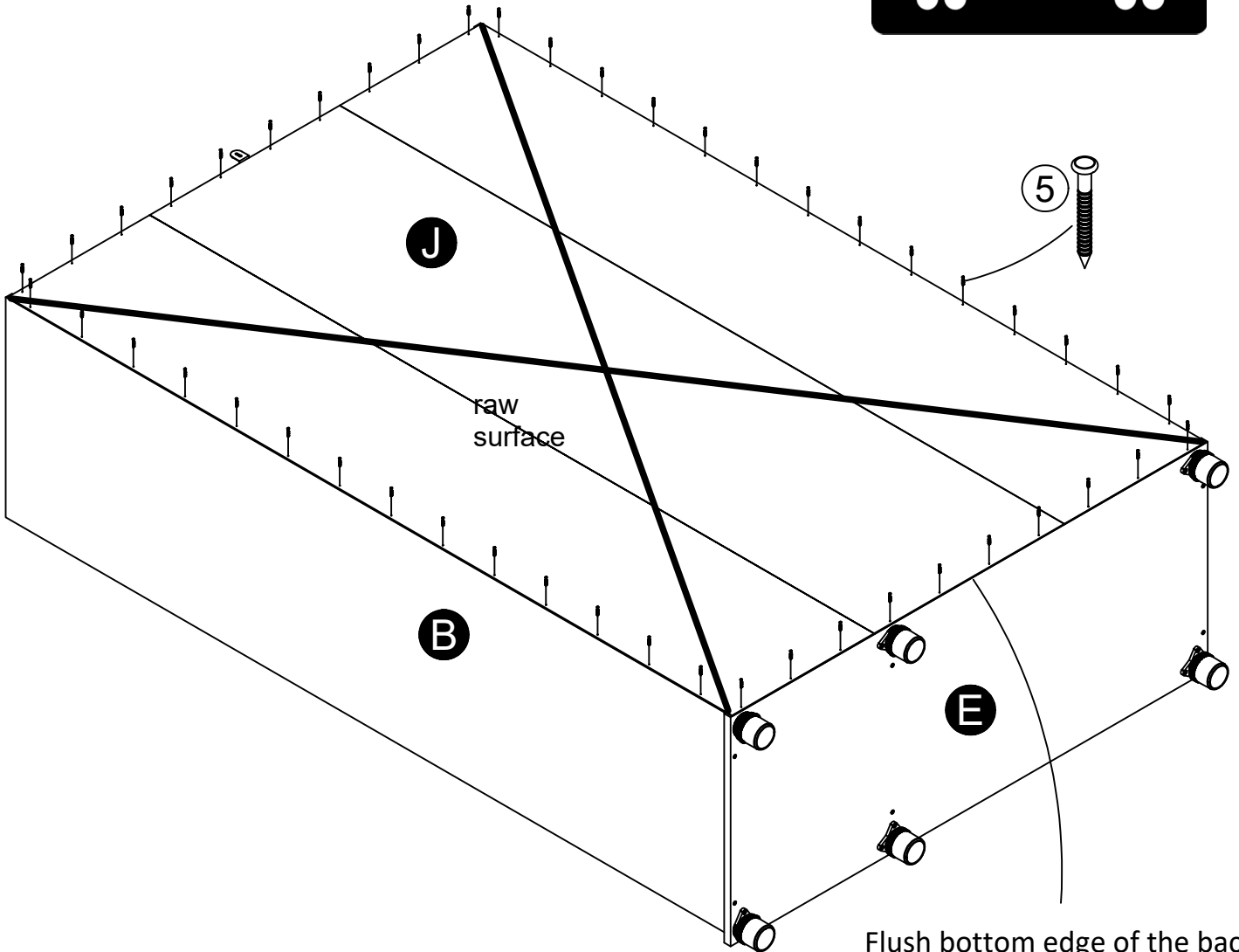
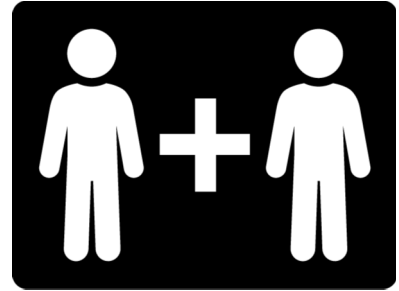

Flush bottom edge of the back panel with the bottom edge of bottom (E).

STEP 14

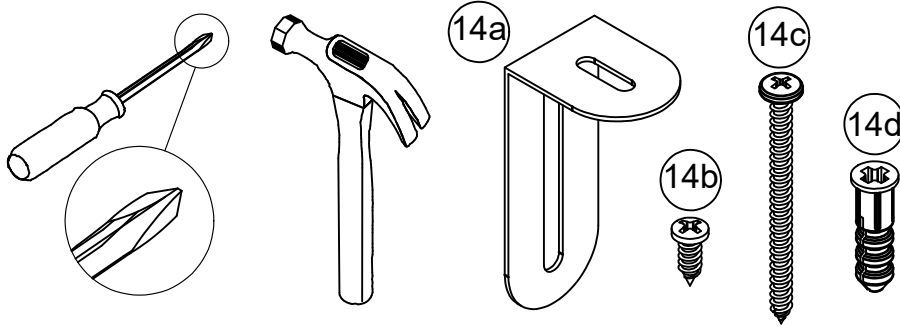

For Masonry, Concrete, or other wall materials:
Consult your local hardware store for appropriate anchors to securely attach the safety bracket.

IMPORTANT: THIS UNIT MUST BE SECURE TO THE WALL TO HELP PREVENT TIPOVER. FOLLOW THESE INSTRUCTIONS TO INSTALL THE ANTI-TIPPING SAFETY BRACKET PROVIDED WITH THIS PRODUCT.

WARNING

Serious or fatal crushing injuries can occur from furniture tipover.

To prevent tipover:

- * Install tipover restraint provided
- * Place heaviest items in the lowest drawers
- * Unless specifically designed to accommodate, do not set TVs or other heavy objects on the top of this product
- * Never allow children to climb or hang on drawers, door, or shelves
- * Never open more than one drawer at a time

Use of tipover restraints may only reduce, but not eliminate the risk of tipover

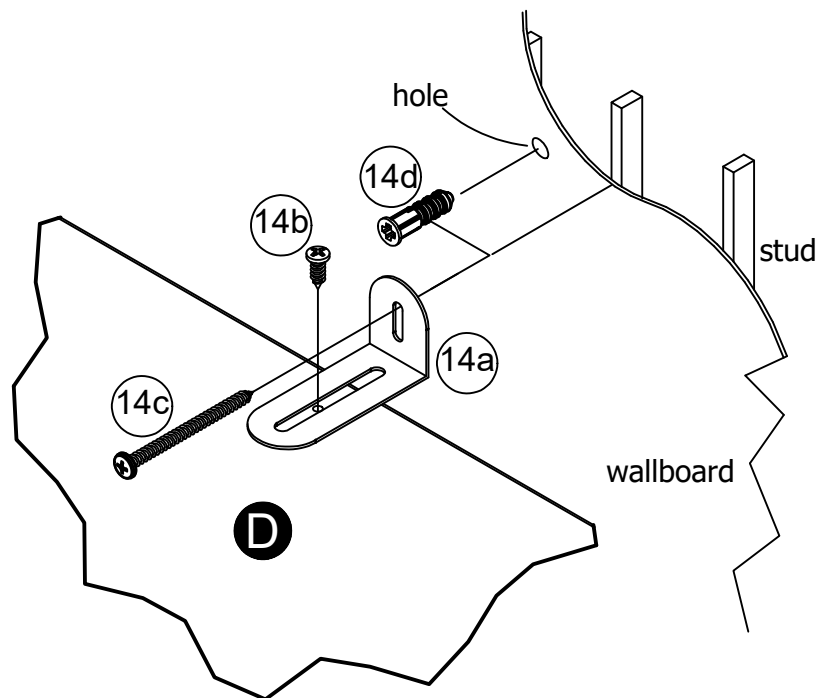

OPTION 1: Attachment into a wall stud (preferred method)

Using a stud finder, locate a stud in the wall. Place your unit against the wall, with the safety bracket aligned in this location. To make driving the screw easier, you can drill a 1/8" diameter pilot hole (3mm) through the safety bracket into the stud. Drive the screw through the safety bracket into the wall stud.

OPTION 2: Attachment into drywall

Locate your unit where desired against a wall and mark the wall through the safety bracket, then move your unit aside. Drill a 3/16" diameter hole (5mm) into the wallboard. Tap the wall anchor into the hole until it is flush. Move your unit into location and fasten the wall bracket to the wall anchor with the screw.

STEP 15

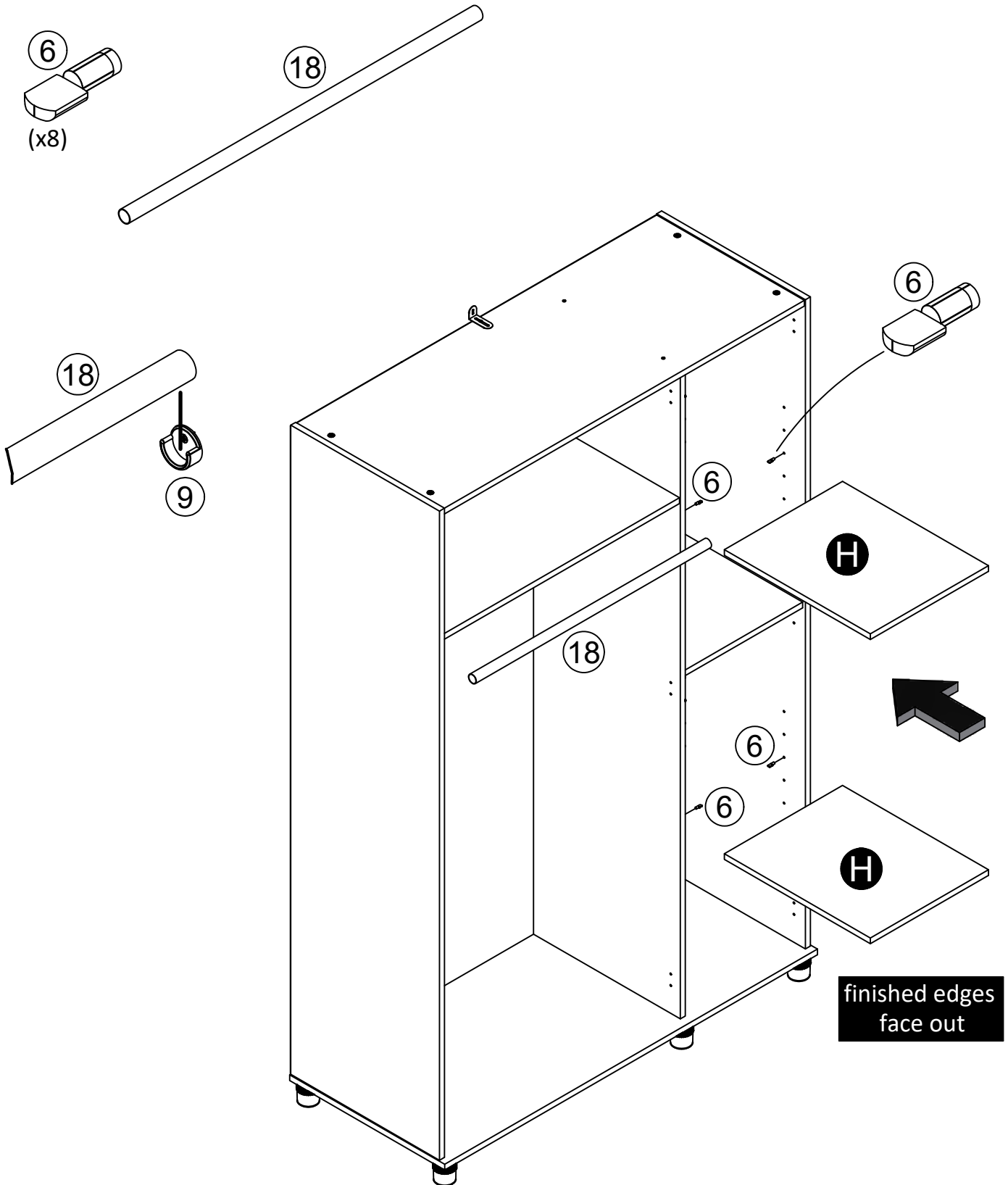

STEP 16

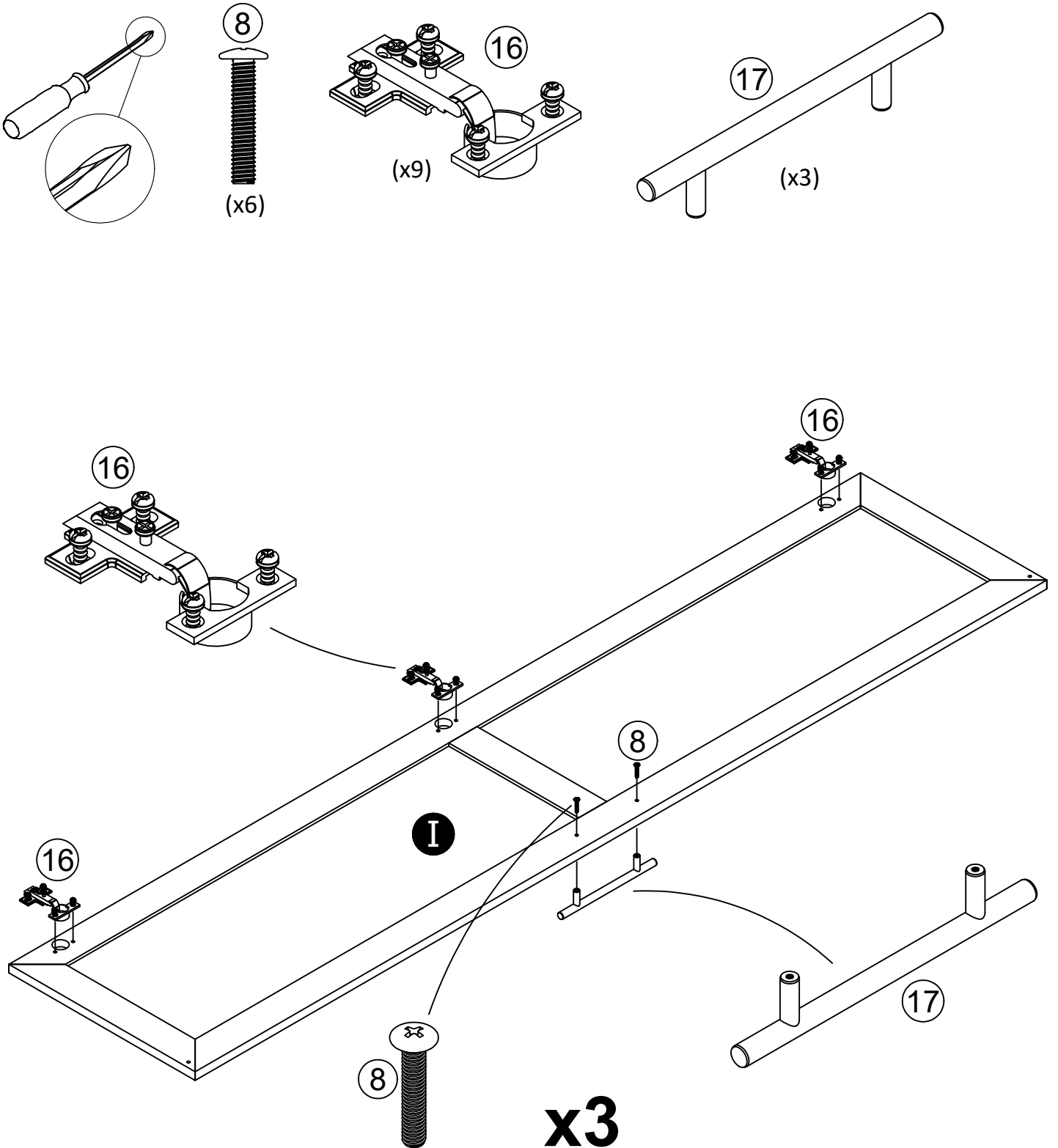

STEP 17

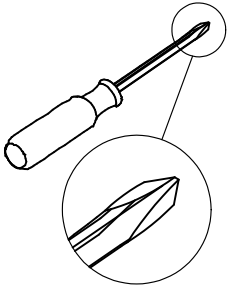

Insert door bumper (11) at top corner of each door.

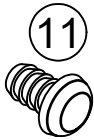

I

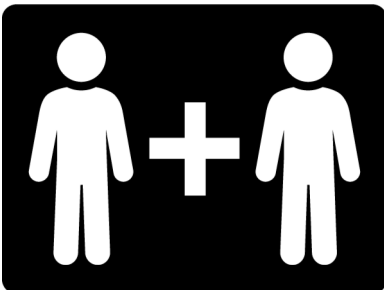
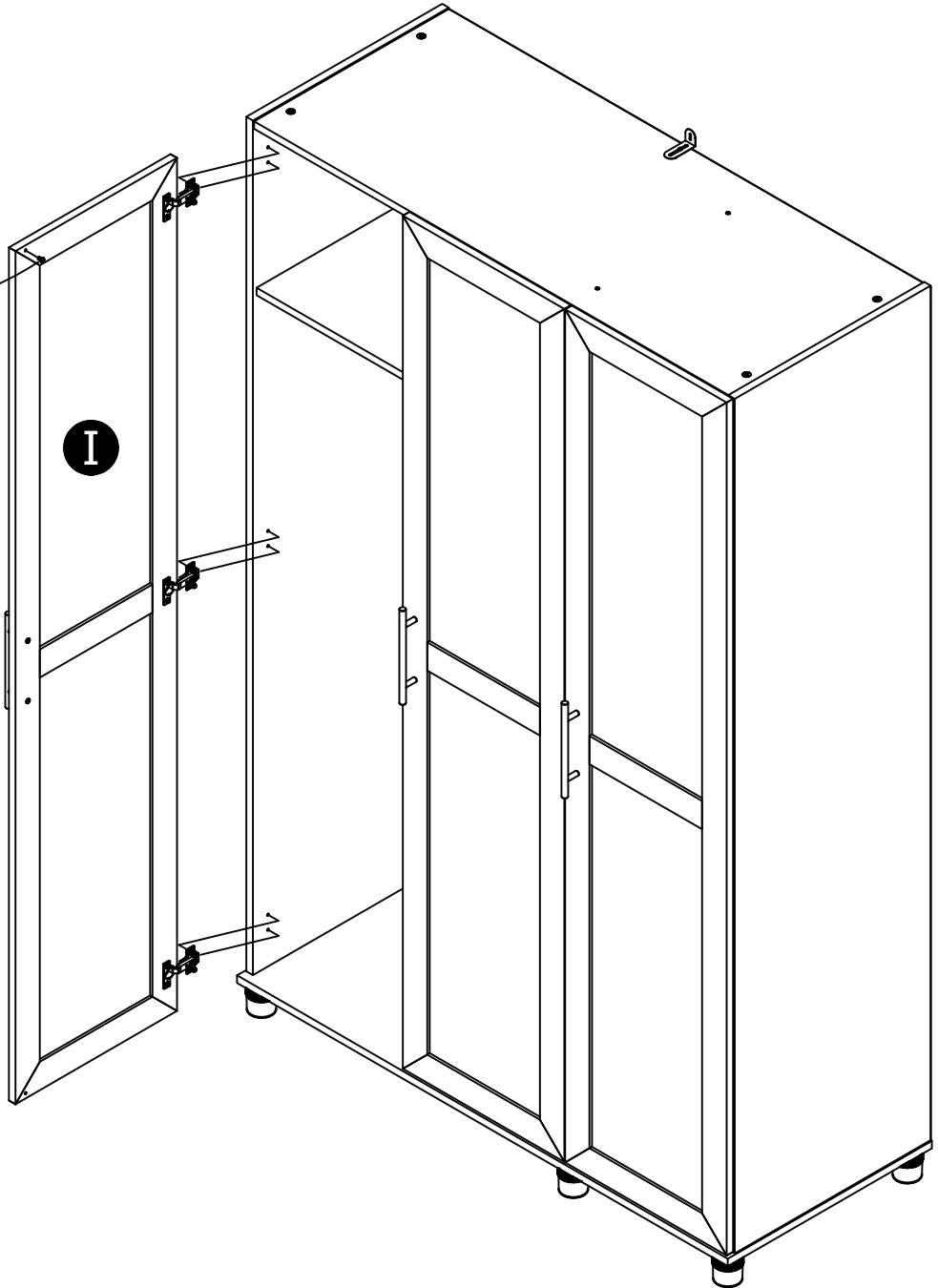
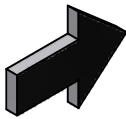

STEP 18

Door Adjustment

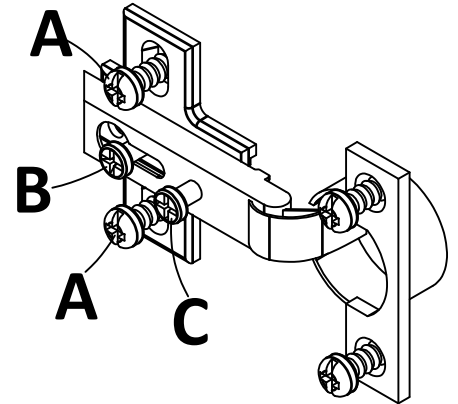
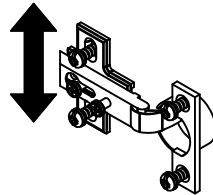
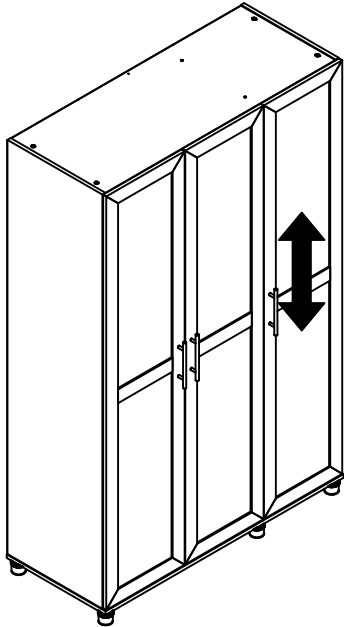
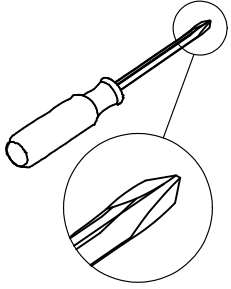

To adjust the vertical height:
Loosen the screws "A" on both hinges. They are usually in slotted holes which allows you to adjust up or down by a few mm. Then tighten back up.

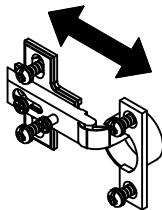
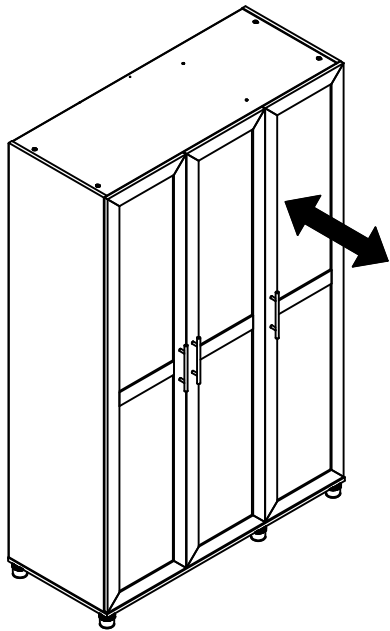

To adjust the depth:
Loosen the screw "B" and adjust door.

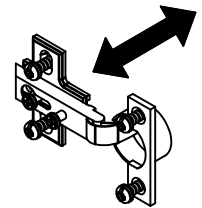
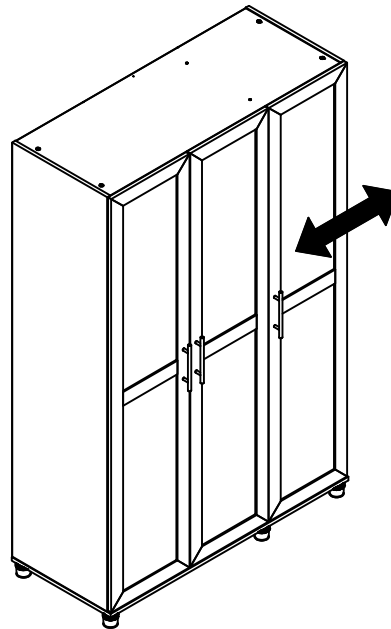

To adjust side to side:
Loosen the screw "C" on BOTH hinges and tighten "B" moves door outward. Loosen "B" and tighten "C" moves doors inward.

Maximum Loads

This unit has been designed to support the maximum loads shown. Exceeding these load limits could cause sagging, instability, product collapse, and/or serious injury.

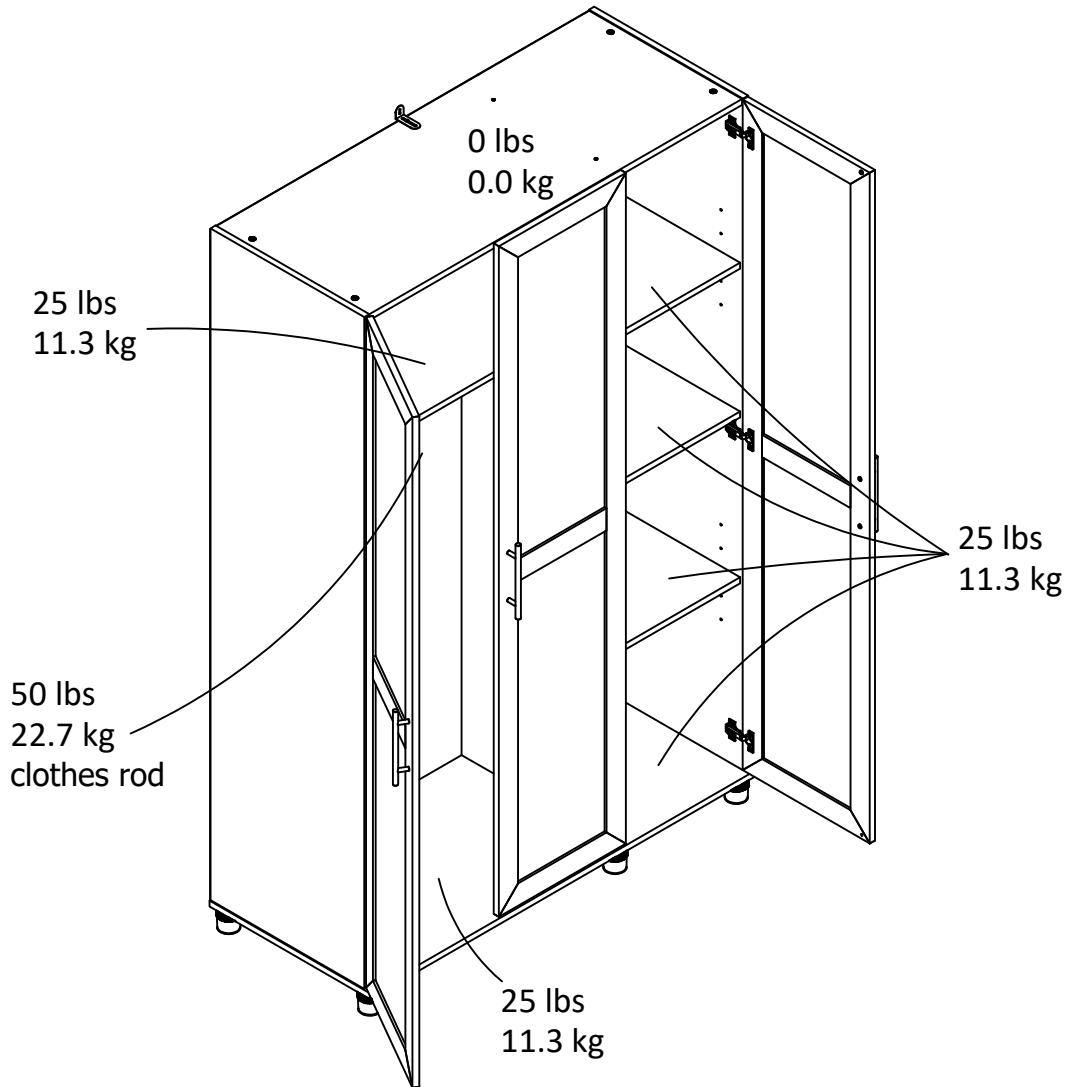

Warning: Risk of injury to persons - do not place a television on this furniture. This furniture is not approved for use with a television.

Certificate of Conformity

1. This certificate applies to the Dorel Home Furnishings, Inc. product identified by this instruction manual.
2. This certificate applies to compliance of this product with the CPSC Ban on Lead-Containing Paint (16 CFR 1303).
3. This product is distributed by: Dorel Home Furnishings, Inc.
410 East First Street South
Wright City, MO 63390
636-745-3351
4. Site of Manufacture: Tiffin OH
5. See front page of instruction manual for date of manufacture.

Register your product to receive the following:



- * New trend details - sneak peek on what's new
- * Surveys - have a voice within our community
- * Exclusive deals and discount codes
- * Quick and easy replacement part service

To register your product, visit systembuild.com

5 Star Rating



Visit your local retailer's website, rate your purchased product and leave us some feedback!

We would like to extend a big "Thank You" to all of our customers for taking the time to assemble this Systembuild product, and to give us your valuable feedback.

*Thank
You!*

Cubierta Delantera

Este libro de instrucciones contiene información **IMPORTANTE** de seguridad. Por favor lea y manténgalo para referencia en el futuro.

No Regrese este producto! Comuníquese con nuestro amistoso equipo de servicio al cliente para obtener ayuda.

Llámenos al: 1-866-452-4081 (Gratis) Lunes - Viernes 9am - 5pm CST

Visitar: www.systembuild.com

PRECAUCION

Este mueble puede volcarse y causar graves heridas y/o muerte.

Anclar el mueble a un poste de madera en la pared (si esto se requiere).

No Permita que los niños monten el mueble.

Mantenga los artículos más pesados en los cajones de abajo.

Consejos Útiles (página 2)

- Abra su artículo en el área donde usted planea utilizarlo para evitar levantar y moverlo menos
- Identificar, ordenar y contar las piezas antes de intentar ensamblar
- Las clavijas de compresión se golpean con un martillo
- Las diapositivas están marcadas con una R (derecha) y L (izquierda) para la colocación correcta
- Asegúrese de que siempre este el punto localizado en la parte superior de bloqueador de leva este volteado hacia borde exterior
- Utilizar todos los clavos para el panel de atrás y distribuirlos por igual
- El panel de atrás debe utilizarse para asegurarse de que la unidad quede fija y firme
- No use químicas fuertes ni limpiadores abrasivos en este artículo
- Nunca empuje, tire ni arrastre los muebles

Antes de Que Empieces (página 3)

- Lea cuidadosamente cada paso y siga el orden correcto
- Separar y contar todas sus piezas y hardware
- Dése suficiente espacio para el proceso de ensamble
- Tenga las siguientes herramientas: destornillador de cabeza plana, #2 cabeza Phillips Destornillador y martillo
- Precaución: Si usa un taladro electrónico o un destornillador eléctrico para atornillar, por favor asegúrese que deje de atornillar cuando el tornillo este apretado. Fallar hacer esto puede causar barrer el tornillo.

Sistema de fijar el bloqueo de leva (página 3)

Este sistema de fijar el bloqueo de leva será usado en todo el proceso de ensamble.

Página 21

IMPORTANT: El Panel trasero es una parte estructural de la unidad y debe ser instalado correctamente.

Gire cuidadosamente su unidad en su parte frontal.

Unido el panel posterior como se muestra clavando directamente en los bordes crudos.

Asegúrese de que la unidad es cuadrada.

La distancia de una esquina a una esquina debe ser igual como se muestra.

Asegúrese de que nuestra unidad es cuadrada.

Distancia de esquina a esquina
debe ser igual como se muestra.

Borde inferior vaciado del panel posterior con el borde inferior de la parte inferior (E).

Página 22

Para mampostería, concreto u otro tipo de paredes:

Acude a tu ferretería local para obtener los anclajes adecuados para fijar de forma segura el soporte de seguridad.

IMPORTANTE: ESTA UNIDAD DEBE ASEGURARSE A UNA PARED PARA EVITAR QUE SE VUELQUE. SIGUE ESTAS INSTRUCCIONES PARA INSTALAR EL SOPORTE DE SEGURIDAD ANTICAÍDA QUE SE PROPORCIONA JUNTO CON ESTE PRODUCTO.

ADVERTENCIA

Un mueble al volcarse puede provocar heridas por aplastamiento que pueden resultar graves o mortales.

Para prevenir que un mueble se vuelque:

* Instala el dispositivo contra caídas que se proporciona

* Coloca los artículos más pesados en los cajones de más abajo

* A menos que esté específicamente diseñado para tal fin, no coloques televisiones ni ningún otro objeto pesado sobre este mueble

* Nunca permitas que los niños se suban o cuelguen de los cajones, puertas o repisas.

* Nunca abras más de un cajón a la vez

El uso de los dispositivos contra caídas puede reducir, pero no eliminar por completo el riesgo de que el mueble se vuelque.

OPCIÓN 1: acoplado a un travesaño de la pared (método recomendado)

Ubica un travesaño en la pared utilizando un localizador de travesaños. Coloca tu unidad contra la pared, con el soporte de seguridad alineado en ese lugar. Para facilitar la entrada del tornillo, puedes perforar un agujero guía de 1/8" (3 mm) de diámetro a través del soporte de seguridad hasta llegar al travesaño. Introduce el tornillo en el travesaño de la pared a través del soporte de seguridad.

OPCIÓN 2: acoplado a un panel de pared

Coloca tu unidad en el lugar deseado contra una pared y marca la pared a través del soporte de seguridad, luego retira tu unidad hacia un lado. Perfora un agujero de 3/16" de diámetro (5 mm) en el tablero de la pared. Golpea el anclaje de pared para introducirlo en el agujero hasta que quede a ras. Vuelve a colocar tu unidad en su lugar y sujeta el soporte de pared al anclaje de pared con el tornillo.

Página 25

Inserte el parachoques de la puerta (11) en la esquina superior de cada puerta.

Página 26

Para ajustar la altura vertical:

Afloje los tornillos "A" en ambas bisagras. Por lo general, están en agujeros ranurados que le permite ajustar hacia arriba o hacia abajo por unos pocos mm. A continuación, apriete de nuevo.

Para ajustar la profundidad:

Afloje el tornillo "B" y ajuste la puerta.

Para ajustar de lado a lado:

Afloje el tornillo "C" en ambas bisagras y apriete el "B" mueve la puerta hacia afuera. Afloje el "B" y apriete el "C" mueve las puertas hacia adentro.

Página 27

CARGA MAXIMA

Esta unidad ha sido diseñada para soportar la carga máxima anotada. El exceder estos límites puede causar inestabilidad, colapsarse y/o causar serias lesiones.

ADVERTENCIA: Riesgo de lesiones a las personas - no coloque un televisor sobre muebles. Este mueble no está aprobado para su uso con un televisor.

Página 28

Registre su producto para recibir lo siguiente:

- * Detalles de nuevas tendencias - Vistazo a lo nuevo
- * Encuestas - aloc su voz entre su comunidad
- * Códigos de ofertas y descuentos exclusivos
- * Fácil y rápido servicio de partes de remplace

Para registrar su producto, visite systembuild.com

Clasificación de 5 estrellas

Visite el sitio web de su tienda local, califique su comprado y denos sus comentarios!

Nos gustaría enviar un gran "Agradecimiento" a todos nuestros clientes por tomarse el tiempo de ensamblar este producto de Systembuild, y por darnos sus valiosos comentarios.

Gracias

Couverture Avant

CE LIVRET D'INSTRUCTION CONTIENT DES INFORMATIONS **IMPORTANTES** SUR LA SÉCURITÉ. VEUILLEZ LIRE ET GARDER POUR UNE RÉFÉRENCE FUTURE

Ne retournez pas ce produit! Contactez notre équipe de service à la clientèle amicale d'abord pour obtenir de l'aide.

Appelez-nous: 1-866-452-4081 (sans frais) du Lundi au Vendredi de 9h à 17h Heure Centrale

Visitez: www.systembuild.com

ATTENTION

Le meuble peut basculer et causer des blessures graves ou la mort.

Ancrer le meuble à une planche murale dans le mur (si indiqué).

Ne laissez pas les enfants grimper sur le meuble.

Placez les articles lourds sur les étagères ou dans les tiroirs inférieurs.

Astuces Utiles (page 2)

-Ouvrez votre article dans la zone que vous prévoyez de le garder pour moins de levage lourd

-Identifier, trier et compter les pièces avant d'essayer d'assembler

-Les goujons de compression sont taraudés avec un Marteau

-Les glissières sont marquées d'un R (droit) et d'un L (gauche) pour un bon placement

-Assurez-vous toujours de faire face la pointe situé sur le haut de la Serrure de Came vers le bord extérieur

-Utiliser tous les clous fournis pour le panneau arrière et les répartir également

-Le panneau arrière doit être utilisé pour vous assurer que votre appareil est robuste

-N'utilisez pas de produits chimiques agressifs ou de nettoyeurs abrasifs sur cet appareil

-Ne jamais pousser, tirer, ou faire glisser votre meuble

Avant de Commencer (page 3)

-Lisez attentivement chaque étape et suivez le bon ordre

-Séparez et comptez toutes vos pièces et matériaux

-Donnez-vous suffisamment de place pour l'assemblage

-Avoir les outils suivants: tournevis à tête plate, #2 tournevis Phillips, et Marteau

-Attention: Si vous utilisez une perceuse électrique ou un tournevis électrique pour visser, veillez à ralentir et arrêter lorsque la vis est bien serrée. Le non-respect de cette consigne peut endommager la vis.

Système de Fixation de Came (page 3)

Ce Système de Fixation de Came sera utilisé tout au long de l'assemblage

Page 21

IMPORTANT: Le panneau arrière est une partie structurelle de cet appareil et doit être installé correctement.

Tournez soigneusement votre appareil sur son côté avant.

Attaché le panneau arrière comme indiqué clouage directement dans les bords bruts.

Assurez-vous que l'appareil est carré.

La distance d'un coin à l'autre doit être égale comme indiqué.

Assurez-vous que notre unité est carrée.

La distance d'un coin à l'autre doit être égale comme indiqué.

Rincer le bord inférieur du panneau arrière avec le bord inférieur du bas (E).

Page 22

Pour la maçonnerie, le béton ou d'autres matériaux de mur :

Visiter votre quincaillerie locale pour obtenir des ancrs appropriés qui permettront de fixer solidement le support de sécurité.

IMPORTANT : CE MEUBLE DOIT ETRE SÉCURISÉ AU MUR POUR EVITER QU'IL NE BASCULE. SUIVRE CES INSTRUCTIONS POUR INSTALLER LE SUPPORT DE SÉCURITÉ ANTI-BASCULEMENT FOURNI AVEC CE PRODUIT.

AVERTISSEMENT

Des blessures graves ou mortelles peuvent se produire en cas de basculement des meubles.

Pour éviter le basculement :

* Installer la pièce anti-basculement fournie

* Placer les objets les plus lourds dans les tiroirs les plus bas

* Sauf si spécifiquement conçu pour y être installé, ne pas poser de téléviseur ou d'autres objets lourds sur de ce produit

* Ne jamais laisser enfants grimper ou s'accrocher sur les tiroirs, les portes ou les étagères

* Ne jamais ouvrir plus d'un tiroir à la fois

L'utilisation des pièces anti-basculement peut uniquement réduire, mais pas éliminer le risque de basculement.

OPTION 1 : ancrage sur un colombage (méthode privilégiée)

Localisez un colombage dans le mur à l'aide d'un détecteur de colombage. Placez votre meuble contre le mur en maintenant le support de sécurité aligné au même endroit. Pour faciliter l'insertion de la vis, il est recommandé de percer un trou d'essai de 1/8" de diamètre (3 mm) à travers le support de sécurité dans le colombage. Passer la vis à travers le support de sécurité pour l'insérer dans le colombage.

OPTION 2 : ancrage dans la cloison sèche

Positionnez votre meuble sur la zone ciblée contre un mur et faites une marque sur le mur à travers le support de sécurité, puis déplacez votre meuble de côté. Percez un trou de 3/16" de diamètre (5 mm) dans le panneau mural. Tapez sur l'ancre murale pour l'introduire dans le trou jusqu'à ce qu'il soit parfaitement aligné et installé. Placez votre meuble sur son emplacement et fixer le support mural à l'ancre murale avec la vis.

Página 25

Insérez le pare-chocs de porte (11) dans le coin supérieur de chaque porte.

Page 26

Pour ajuster la hauteur verticale :

Desserrez les vis "A" sur les deux charnières. Ils sont généralement dans des trous à fentes qui vous permet de s'ajuster vers le haut ou le bas de quelques mm. Puis resserrez-vous.

Pour ajuster la profondeur :

Desserrez la vis "B" et ajustez la porte.

Pour s'adapter d'un côté à l'autre :

Desserrer la vis "C" sur les DEUX charnières et serrer "B" ajuste la porte vers l'extérieur. Desserrer "B" et serrer "C" ajuste les portes vers l'intérieur.

Page 27

CHARGES MAXIMALES

Ce meuble a été conçu pour supporter les charges maximales indiquées. En excédant ces limites de charge, le meuble pourrait devenir instable, s'effondrer, et/ou causer des blessures graves.

AVERTISSEMENT : Risque de blessure corporelle - ne pas placer une télévision sur ce meuble. Ce meuble n'est pas approuvé pour une utilisation avec une télévision.

Page 28

Enregistrez votre produit pour recevoir les éléments suivantes:

- * Détails sur les nouvelles tendances - un aperçu sur les nouveautés
- * Sondages - avoir une voix au sein de notre communauté
- * Offres exclusives et codes promo
- * Service de pièces de rechange rapide et facile

Pour enregistrer votre produit, visitez systembuild.com

5 Étoiles

Visitez le site Web de votre détaillant local, évaluez votre produit acheté et laissez-nous quelques commentaires !

Nous tenons à offrir un grand "Merci" à tous nos clients pour avoir pris le temps d'assembler ce produit "Systembuild", et de nous donner vos commentaires précieux.

Merci